

# Cam Follower

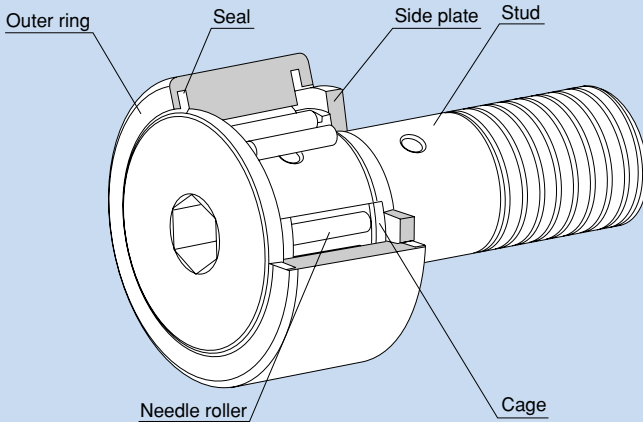

Fig. 1 Structure of Cam Follower Model CF ... UU-A

## Structure and Features

The Cam Follower is a compact and highly rigid bearing with a shaft. It contains needle bearings and is used as a guide roller for cam mechanisms or linear motion.

Since its outer ring rotates while keeping direct contact with the mating surface, this product is thick-walled and designed to bear an impact load.

Inside the outer ring, needle rollers and a precision cage are incorporated. This prevents the product from skewing and achieves a superb rotation performance. And, as a result, the product is capable of easily withstanding high-speed rotation.

There are two types of the outer ring in shape: spherical and cylindrical. The spherical outer ring easily absorbs a distortion of the shaft center when the cam follower is installed and helps lighten a biased load.

## Applications

The Cam Follower is used in a wide range of applications such as cam mechanisms of automatic machines, dedicated machines as well as carrier systems, conveyors, bookbinding machines, tool changers of machining centers, pallet changers, automatic coating machines, sliding forks of automatic warehouses.

## ● Types and Features

### ● Popular Type Cam Follower

Model CF



It is a popular type of Cam Follower provided with a driver groove on the head of the stud. A highly corrosion resistant stainless steel type (symbol M) is also available.

### ● Cam Follower with a Hexagon Socket

Model CF-A



Since the stud head has a hexagon socket, this model can easily be installed using a hexagon wrench.

A type whose stud screw has a hexagon socket (CF-B) is also available (applicable to stud diameter of 12 or greater).

### ● Eccentric Cam Follower with a Hexagon Socket

Model CFH-A

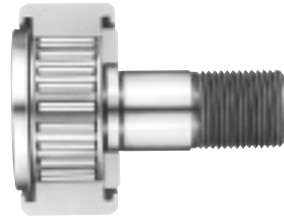

This model can be installed in the same mounting hole as that of model CF. Since the mounting shaft of the stud and the stud head are eccentric by 0.25 mm to 1.0 mm, the position of this model can easily be adjusted simply by turning the stud. Thus, it is a compact, highly accurate eccentric cam follower with an integral structure. As a result, the man-hours for machining and assembly can significantly be reduced because it is unnecessary to align the cam follower with the cam groove and machine the mounting-hole area with precision.

## ● Cam Follower Containing Thrust Balls

### Model CFN



Based on the popular type Cam Follower, this model is incorporated with thrust load balls.

Model CFN is capable of receiving an axial load generated due to a mounting error.

## ● Cam Follower with a Tapped Hole for Greasing

### Model CFT



Basically the same as the popular type Cam Follower, this model is provided with tapped holes for piping on the stud head and the thread.

It is optimal for locations where an integrated piping for greasing is required.

# Types and Model Numbers

The Cam Follower is divided into several types as indicated in table 1.

Table 1 Types and Model Numbers of Cam Followers

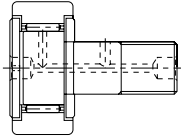
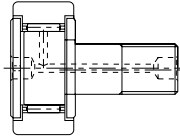
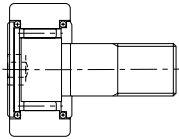
Type		Popular type	Eccentric Cam Follower	Containing thrust balls
Shape				
Cylindrical outer ring	Stud with a hexagon socket	CF-A (CF...UU-A)	CFH-A (CFH...UU-A)	-----
	Stud with a driver groove	CF (CF...UU)	CFH (CFH...UU)	-----
	With a tapped hole for greasing	CFT (CFT...UU)	CFHT (CFHT...UU)	-----
	Made of stainless steel	CF-M (CF...MUU)	CFH-M (CFH...MUU)	-----
Spherical outer ring	Stud with a hexagon socket	CF-R-A (CF...UUR-A)	CFH-R-A (CFH...UUR-A)	CFN-R-A
	Stud with a driver groove	CF-R (CF...UUR)	CFH-R (CFH...UUR)	-----
	With a tapped hole for greasing	CFT-R (CFT...UUR)	CFHT-R (CFHT...UUR)	-----
	Made of stainless steel	CF-MR (CF...MUUR)	CFH-MR (CFH...MUUR)	-----

Note 1: The symbols in the parentheses indicate model numbers of types with seals.

Note 2: THK also manufactures low-speed full-roller types with long service lives. For these full-roller types, symbol "V" is indicated.

Note 3: Symbol M indicates a stainless steel type.

Example: **CF 12 V UUR**

└ Full-roller type

# Accuracy Standards

Cam Followers are manufactured with accuracies according to table 2.

- ① Dimensional tolerance of the cylindrical outer ring in outer diameter D: table 2
- ② Dimensional tolerance of the spherical outer ring in outer diameter D:  $\begin{matrix} 0 \\ -0.05 \end{matrix}$
- ③ Dimensional tolerance of the Cam Follower in stud diameter d: h7
- ④ Dimensional tolerance of the outer ring in width B:  $\begin{matrix} 0 \\ -0.12 \end{matrix}$

Table 2 Accuracy of the Outer Ring (JIS Class 0)  
Unit:  $\mu\text{m}$

Nominal dimension of the bearing outer diameter (D) (mm)		Tolerance of the bearing in outer diameter (Dm) <small>(nom)</small>		Tolerance of the outer ring in radial run-out (max)
Above	Or less	Upper	Lower	
6	18	0	- 8	15
18	30	0	- 9	15
30	50	0	-11	20
50	80	0	-13	25
80	120	0	-15	35

Note: "Dm" represents the arithmetic average of the maximum and minimum diameters obtained in measuring the bearing outer diameter at two points.

## Radial Clearance

The radial clearances of Cam Followers meet clearance C2 (see table 3).  
(Normal clearance applies to full-roller types.)

Table 3 Radial Clearance

Unit:  $\mu\text{m}$ 

Model No.: CF, CFN, CFH and CFT	Clearance C2		Normal clearance	
	Min.	Max.	Min.	Max.
3 to 4	3	17	10	25
5 to 8	5	20	15	30
10 to 12-1	5	25	15	35
16 to 20-1	10	30	20	40
24 to 30-2	10	40	25	55

## Fitting

For the dimensional tolerance of the Cam Follower in stud-mounting hole, we recommend the following fitting.

The dimensional tolerance of the stud-mounting hole: H7

## Installation

### Installing the Cam Follower

Establish perpendicularity between the stud-mounting hole and the mounting surface, and chamfer the mouth of the hole to the smallest possible radius, preferably C0.5. Also, the diameter of the mounting surface should preferably be at least equal to the dimension "f" indicated in the dimensional table.

If the Cam Follower is to be used under a heavy load, it is necessary to install the product so that the greasing hole on the stud is out of the loaded area. To help identify the position of the greasing hole, the THK logo is marked on the side face of the stud collar (see Fig. 2). The vertical hole in the middle of the stud is used as a whirl stop or a greasing hole.

Make sure that the outer ring is evenly in contact with the mating surface. If the outer ring unilaterally or unevenly contacts the mating surface, we recommend using model CF-R, whose outer ring circumference is spherically ground. When installing the Cam Follower, also make sure its axis is perpendicular to the traveling direction.

### Tightening Torque for the Stud

Since the stud of the Cam Follower receives bending stress and tensile stress caused by a bearing load, it is necessary to keep the tightening torque of the screw from exceeding the values indicated in table 4.

If the mounting screw may be loosened due to vibrations or impact, use a spring washer, thin nuts of JIS B 1811 Class 3 as double nuts or a special nut capable of preventing itself from loosening.

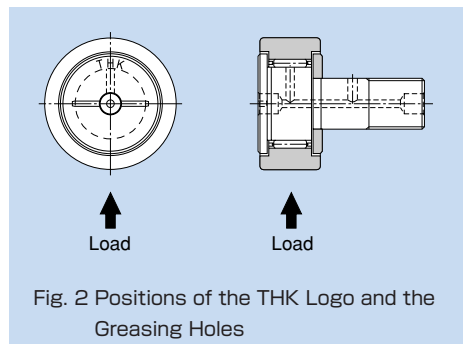
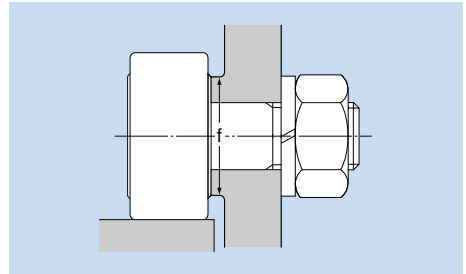

Fig. 2 Positions of the THK Logo and the Greasing Holes

Table 4 Maximum Tightening Torque of the Screw

Model No.: CF, CFN, CFH and CFT	Maximum tightening torque N-m
3	0.392
4	0.98
5	1.96
6	2.94
8	7.84
10 10-1	16.7
12 12-1	29.4
16	70.6
18	98
20 20-1	137
24 24-1	245
30 30-1 30-2	480

Note: 1 N-m equals to 0.102 kgf-m.

## ● Installing the Eccentric Cam Follower

The eccentricity is adjusted in the following steps.

- ① Insert the stud into the mounting hole, and lightly tighten the nut until the nut starts turning. In doing so, position the THK logo in relation to the load direction as shown in Fig. 3.
- ② Use the hexagon socket on the stud head to turn the stud and adjust the clearance between the stud and the mating contact surface.
- ③ After adjusting the clearance, tighten the nut while keeping the stud from turning. Be sure the maximum tightening torque in table 4 is not exceeded.

The surface of the Cam Follower stud is hardened. Take this into account when machining the stud.

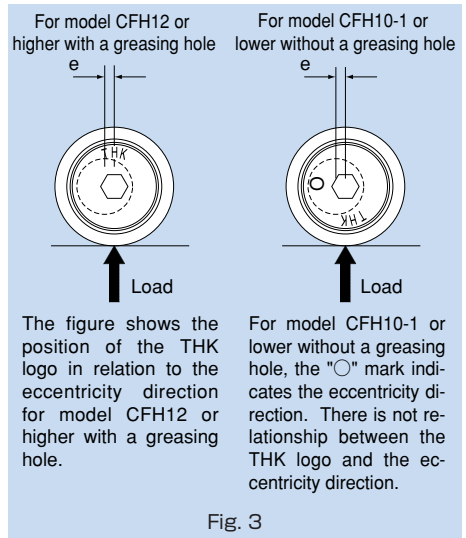

## ● Cam Follower with a Hexagon Socket

For Cam Follower model CF, Cam Follower Containing Thrust Balls model CFN and Eccentric Cam Follower model CFH, hexagon socket studs that allow easy eccentricity adjustment are available. If desiring a hexagon socket on the stud head, add "A" to the end of the model number. If desiring a hexagon socket on the stud thread, add "B" ("B" applies to model CF12 or higher).

## ● Cam Follower Containing Thrust Balls

Even a slight mounting error in a high-speed cam mechanism operating in a harsh environment could cause abnormal wear to the thrust unit of the cam follower. In such a case, using Cam Follower Containing Thrust Balls model CFN will bring about a significant effect in increasing the durability.

Models CFN5 to 12 are standard-stock items. If desiring a size other than the standard items, contact **THK**.

Model CFN is capable of receiving a thrust load caused by a slight mounting error. However, it is necessary to minimize a component of thrust force, or prevent it from occurring, when designing the cam mechanism and installing the Cam Follower.

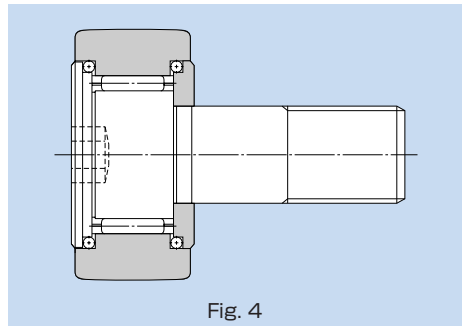

## Dust Prevention and Lubrication

The Cam Follower models include seal types (model numbers: "...UU"), which are incorporated with special synthetic rubber seals that are highly resistant to wear in order to prevent foreign matter from entering the interior of the cam follower and the lubricant from leaking.

Since each Cam Follower unit with seals contains high-quality lithium soap group grease No. 2, you can start using the product without replenishing grease. Exceptionally, model CFN contains AFC Grease.

If your Cam Follow does not have seals, fill grease from the greasing hole on the stud or the inner ring. However, some of the model numbers with stud diameters of 10 mm or less do not have a greasing hole and are provided with initial lubrication only, and therefore do not allow replenishment of grease.

The appropriate fill quantity is a half to one third of the space inside the bearing. The lubrication interval varies depending on the operating conditions. As a guide, however, replenish grease of the same group every six months to two years for types with a cage, or every one to 6 months for full-roller types.

Even with types equipped with seals ("...UU"), surplus grease may seep during the initial operation period or immediately after grease replenishment. If desiring to avoid contamination of the surrounding area of the machine by grease, first perform seasoning or the like in advance, and then wipe the seeping surplus grease.

When driving the dedicated grease nipple onto the Cam Follower, use a jig like the one shown in Fig. 5 to provide pressure to the flange of the nipple.

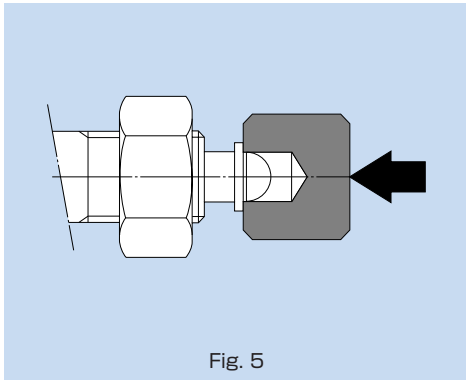

Fig. 5

## Accessories for the Cam Follower

Table 5 shows accessories for standard types of Cam Followers. The dedicated grease nipple is attached at your request. If desiring the dedicated grease nipple, add symbol "N" to the end of the model number.  
Example: CF12UUR-N

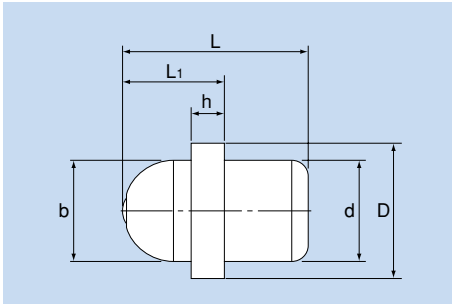

Table 5 Accessories

Model No.		Stopper cap <small>(note 1)</small>	Stud plug <small>(note 2)</small>	Nut JIS Class 2	Grease <small>(note 3)</small>
CF	Without seal	Included in package	Included in package	Included in package	Not contained
CFH	With seal	Included in package	Included in package	Included in package	Contained
CFN		Included in package	Included in package	Included in package	Contained
CFT	Without seal	—	—	Included in package	Not contained
	With seal	—	—	Included in package	Contained

Note 1: The stopper cap is used to prevent grease from leaking. However, it is not included in the packages of model CF5, and hexagon socket types of models CFN10 (R)-A and CF (CFH) 10-1 (R)-A or lower.

Note 2: The stud plug is used to close an unused greasing hole. However, it is not attached to model CF (CFH) 10-1 -A or lower.

Note 3: All models without a greasing hole are filled with grease when assembled regardless of whether a seal is attached or not.

Table 6 Dimensional Table for Grease Nipples

Supported models	Nipple dimensions						Nipple model No.
	d	b	D	h	L	L <sub>1</sub>	
CF, CFN and CFH							
5	3.1	6	7.5	1.5	9	5.5	NP3.2X3.5
6 to 10	4	6	7.5	1.5	10	5.5	PB1021B
12 to 18	6	6	8	2	11	6	NP6X5
20 to 30	8	6	10	3	16	7	NP8X9

Note: The grease nipple is not attached to models CFN10 (R)-A and CF (CFH) 10-1 (R)-A or lower.

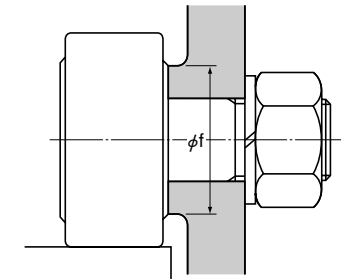
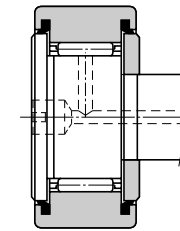
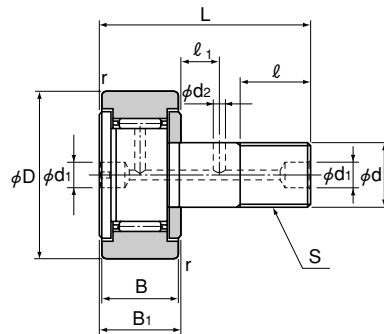

Model CF ... UU

Unit: mm

Stud diameter d	Model No. Cylindrical outer ring	Major dimensions											Basic load rating		Maximum permissible load F <sub>0</sub> kN	Track load capacity kN	Rotational speed limit** min <sup>-1</sup>	Mass g
		Outer diameter D	Thread S	Outer ring width B	B <sub>1</sub>	Overall length L	d <sub>1</sub>	d <sub>2</sub>	l	l <sub>1</sub>	r	Shoulder height f (Min.)	C kN	C <sub>0</sub> kN				
5	CF 5	13	M5X0.8	9	10	23	3.1*	—	7.5	—	0.5	9.7	3.14	2.77	1.42	2.25	29000	10.5
6	CF 6	16	M6X1	11	12	28	4*	—	9	—	0.5	11	3.59	3.58	2.11	3.43	25000	18.5
8	CF 8	19	M8X1.25	11	12	32	4*	—	11	—	0.5	13	4.17	4.65	4.73	4.02	20000	28.5
10	CF 10	22	M10X1.25	12	13	36	4*	—	13	—	1	15	5.33	6.78	5.81	4.7	17000	45
10	CF 10-1	26	M10X1.25	12	13	36	4*	—	13	—	1	15	5.33	6.78	5.81	5.49	17000	60
12	CF 12	30	M12X1.5	14	15	40	6	3	14	6	1.5	20	7.87	9.79	9.37	7.06	14000	95
12	CF 12-1	32	M12X1.5	14	15	40	6	3	14	6	1.5	20	7.87	9.79	9.37	7.45	14000	105
16	CF 16	35	M16X1.5	18	19.5	52	6	3	18	8	1.5	24	12	18.3	17.3	11.2	10000	170
18	CF 18	40	M18X1.5	20	21.5	58	6	3	20	8	1.5	26	14.7	25.2	26.1	14.4	8500	250
20	CF 20	52	M20X1.5	24	25.5	66	8	4	22	9	1.5	36	20.7	34.8	32.1	23.2	7000	460
20	CF 20-1	47	M20X1.5	24	25.5	66	8	4	22	9	1.5	36	20.7	34.8	32.1	21	7000	385
24	CF 24	62	M24X1.5	29	30.5	80	8	4	25	11	1.5	40	30.6	53.2	49.5	34.2	6500	815
24	CF 24-1	72	M24X1.5	29	30.5	80	8	4	25	11	1.5	40	30.6	53.2	49.5	39.8	6500	1140
30	CF 30	80	M30X1.5	35	37	100	8	4	32	15	2	46	45.4	87.6	73.7	52.6	5000	1870
30	CF 30-1	85	M30X1.5	35	37	100	8	4	32	15	2	46	45.4	87.6	73.7	56	5000	2030
30	CF 30-2	90	M30X1.5	35	37	100	8	4	32	15	2	46	45.4	87.6	73.7	59.3	5000	2220

**Note** The seal must be used at temperature of 80°C or below.  
Those models marked with "\*" have a greasing hole only on the head.

**Note** The rotation speed limit value in the table (\*\*) applies to models that have no seal and use grease lubrication. With those models using oil lubrication, up to 130% of this value is permitted. With those attached with seals, up to 70% of this value is permitted.  
THK also manufactures full-roller types (stud diameter: 6 to 30 mm).  
For the basic load ratings of full-roller types, see page p-21.

Model number coding

CF10 M UU  
1 2 3

1 Model number 2 Made of stainless steel 3 With seal

# Model CF-R | Model CF-MR

Popular Type (Spherical Outer Ring) | Stainless Steel Type

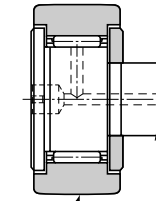
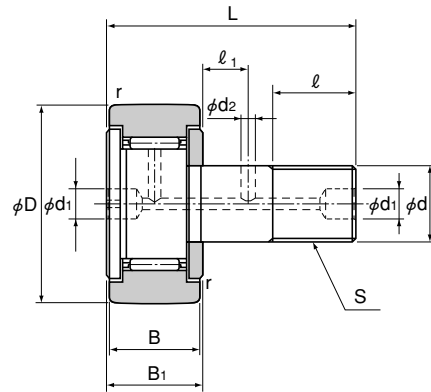

R250 (CF5)  
R500 (CF6 to CF18)  
R1000 (CF20 to CF30)

Model CF-R

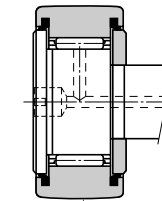

R250 (CF5)  
R500 (CF6 to CF18)  
R1000 (CF20 to CF30)

Model CF ... UUR

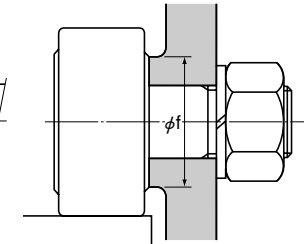

Unit: mm

Stud diameter d	Model No. Spherical outer ring	Outer diameter D	Thread S	Outer ring width B	B <sub>1</sub>	Overall length L	Major dimensions						Basic load rating		Maximum permissible load F <sub>0</sub> kN	Track load capacity kN	Rotational speed limit** min <sup>-1</sup>	Mass g
							d <sub>1</sub>	d <sub>2</sub>	l	l <sub>1</sub>	r	Shoulder height f (Min.)	C kN	C <sub>0</sub> kN				
5	CF 5R	13	M5X0.8	9	10	23	3.1*	—	7.5	—	0.5	9.7	3.14	2.77	1.42	0.53	29000	10.5
6	CF 6R	16	M6X1	11	12	28	4*	—	9	—	0.5	11	3.59	3.58	2.11	1.08	25000	18.5
8	CF 8R	19	M8X1.25	11	12	32	4*	—	11	—	0.5	13	4.17	4.65	4.73	1.37	20000	28.5
10	CF 10R	22	M10X1.25	12	13	36	4*	—	13	—	1	15	5.33	6.78	5.81	1.67	17000	45
10	CF 10-1R	26	M10X1.25	12	13	36	4*	—	13	—	1	15	5.33	6.78	5.81	2.06	17000	60
12	CF 12R	30	M12X1.5	14	15	40	6	3	14	6	1.5	20	7.87	9.79	9.37	2.45	14000	95
12	CF 12-1R	32	M12X1.5	14	15	40	6	3	14	6	1.5	20	7.87	9.79	9.37	2.74	14000	105
16	CF 16R	35	M16X1.5	18	19.5	52	6	3	18	8	1.5	24	12	18.3	17.3	3.14	10000	170
18	CF 18R	40	M18X1.5	20	21.5	58	6	3	20	8	1.5	26	14.7	25.2	26.1	3.72	8500	250
20	CF 20R	52	M20X1.5	24	25.5	66	8	4	22	9	1.5	36	20.7	34.8	32.1	8.23	7000	460
20	CF 20-1R	47	M20X1.5	24	25.5	66	8	4	22	9	1.5	36	20.7	34.8	32.1	7.15	7000	385
24	CF 24R	62	M24X1.5	29	30.5	80	8	4	25	11	1.5	40	30.6	53.2	49.5	10.5	6500	815
24	CF 24-1R	72	M24X1.5	29	30.5	80	8	4	25	11	1.5	40	30.6	53.2	49.5	12.9	6500	1140
30	CF 30R	80	M30X1.5	35	37	100	8	4	32	15	2	46	45.4	87.6	73.7	14.9	5000	1870
30	CF 30-1R	85	M30X1.5	35	37	100	8	4	32	15	2	46	45.4	87.6	73.7	16.1	5000	2030
30	CF 30-2R	90	M30X1.5	35	37	100	8	4	32	15	2	46	45.4	87.6	73.7	17.3	5000	2220

**Note** The seal must be used at temperature of 80°C or below.  
Those models marked with "\*" have a greasing hole only on the head.

**Note** The rotation speed limit value in the table (\*\*) applies to models that have no seal and use grease lubrication. With those models using oil lubrication, up to 130% of this value is permitted. With those attached with seals, up to 70% of this value is permitted.  
THK also manufactures full-roller types (stud diameter: 6 to 30 mm).  
For the basic load ratings of full-roller types, see page p-21.

Model number coding

**CF5 M UU R**

1 2 3 4

1 Model number 2 Made of stainless steel 3 With seal 4 Spherical outer ring

# Model CF-A

Cam Follower with Hexagon Socket (Spherical Outer Ring)

# Model CF-M-A

Stainless Steel Type

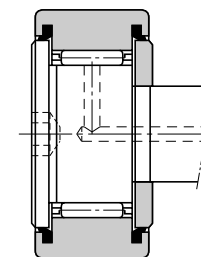
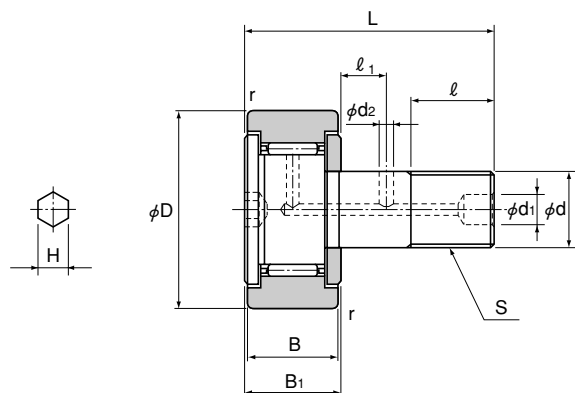

Model CF ... UU-A

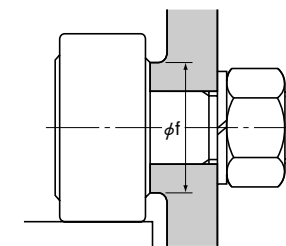

Unit: mm

Stud diameter d	Model No. Cylindrical outer ring	Outer diameter D	Thread S	Outer ring width B	B <sub>1</sub>	Overall length L	Major dimensions							Basic load rating		Maximum permissible load F <sub>0</sub> kN	Track load capacity kN	Rotational speed limit** min <sup>-1</sup>	Mass g
							d <sub>1</sub>	d <sub>2</sub>	l	l <sub>1</sub>	H*	r	Shoulder height f (Min.)	C kN	C <sub>0</sub> kN				
3	CF 3-A	10	M3X0.5	7	8	17	—*	—	5	—	2(1.5)	0.3	6.8	1.47	1.18	0.36	1.37	47000	4.5
4	CF 4-A	12	M4X0.7	8	9	20	—*	—	6	—	2.5(2)	0.5	8.6	2.06	2.05	0.78	1.76	37000	7.5
5	CF 5-A	13	M5X0.8	9	10	23	—*	—	7.5	—	3(2.5)	0.5	9.7	3.14	2.77	1.42	2.25	29000	10.5
6	CF 6-A	16	M6X1	11	12	28	—*	—	9	—	3	0.5	11	3.59	3.58	2.11	3.43	25000	18.5
8	CF 8-A	19	M8X1.25	11	12	32	—*	—	11	—	4	0.5	13	4.17	4.65	4.73	4.02	20000	28.5
10	CF 10-A	22	M10X1.25	12	13	36	—*	—	13	—	5	1	15	5.33	6.78	5.81	4.7	17000	45
10	CF 10-1-A	26	M10X1.25	12	13	36	—*	—	13	—	5	1	15	5.33	6.78	5.81	5.49	17000	60
12	CF 12-A	30	M12X1.5	14	15	40	6	3	14	6	6	1.5	20	7.87	9.79	9.37	7.06	14000	95
12	CF 12-1-A	32	M12X1.5	14	15	40	6	3	14	6	6	1.5	20	7.87	9.79	9.37	7.45	14000	105
16	CF 16-A	35	M16X1.5	18	19.5	52	6	3	18	8	6	1.5	24	12	18.3	17.3	11.2	10000	170
18	CF 18-A	40	M18X1.5	20	21.5	58	6	3	20	8	6	1.5	26	14.7	25.2	26.1	14.4	8500	250
20	CF 20-A	52	M20X1.5	24	25.5	66	8	4	22	9	8	1.5	36	20.7	34.8	32.1	23.2	7000	460
20	CF 20-1-A	47	M20X1.5	24	25.5	66	8	4	22	9	8	1.5	36	20.7	34.8	32.1	21	7000	385
24	CF 24-A	62	M24X1.5	29	30.5	80	8	4	25	11	8	1.5	40	30.6	53.2	49.5	34.2	6500	815
24	CF 24-1-A	72	M24X1.5	29	30.5	80	8	4	25	11	8	1.5	40	30.6	53.2	49.5	39.8	6500	1140
30	CF 30-A	80	M30X1.5	35	37	100	8	4	32	15	8	2	46	45.4	87.6	73.7	52.6	5000	1870
30	CF 30-1-A	85	M30X1.5	35	37	100	8	4	32	15	8	2	46	45.4	87.6	73.7	56	5000	2030
30	CF 30-2-A	90	M30X1.5	35	37	100	8	4	32	15	8	2	46	45.4	87.6	73.7	59.3	5000	2220

**Note** The seal must be used at temperature of 80°C or below.  
Those models marked with "\*" do not have a greasing hole and cannot be replenished with grease.

**Note** "\*" indicates that the dimensions in the parentheses in this row apply to stainless steel types.  
The rotation speed limit value in the table (\*\*) applies to models that have no seal and use grease lubrication. With those models using oil lubrication, up to 130% of this value is permitted. With those attached with seals, up to 70% of this value is permitted.  
THK also manufactures full-roller types (stud diameter: 6 to 30 mm).  
For the basic load ratings of full-roller types, see page p-21.

### Model number coding

CF10 M UU -A

1 2 3 4

1 Model number 2 Made of stainless steel 3 With seal 4 With hexagon socket stud

# Model CF-R-A

Cam Follower with Hexagon Socket (Spherical Outer Ring)

# Model CF-MR-A

Stainless Steel Type

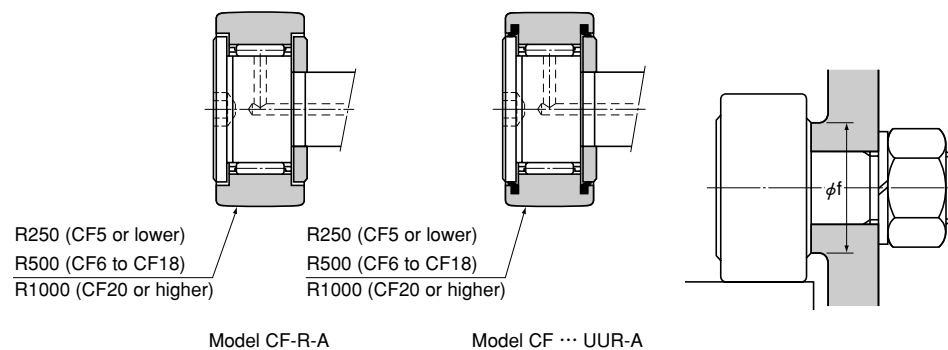
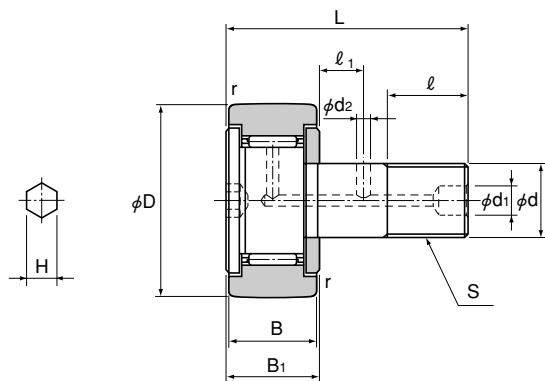

Unit: mm

Stud diameter d	Model No. Spherical outer ring	Outer diameter D	Thread S	Outer ring width B	B <sub>1</sub>	Overall length L	Major dimensions						Basic load rating		Maximum permissible load F <sub>0</sub> kN	Track load capacity kN	Rotational speed limit** min <sup>-1</sup>	Mass g	
							d <sub>1</sub>	d <sub>2</sub>	l	l <sub>1</sub>	H*	r	Shoulder height f (Min.)	C kN					C <sub>0</sub> kN
3	CF 3R-A	10	M3X0.5	7	8	17	—*	—	5	—	2(1.5)	0.3	6.8	1.47	1.18	0.36	0.37	47000	4.5
4	CF 4R-A	12	M4X0.7	8	9	20	—*	—	6	—	2.5(2)	0.5	8.6	2.06	2.05	0.78	0.47	37000	7.5
5	CF 5R-A	13	M5X0.8	9	10	23	—*	—	7.5	—	3(2.5)	0.5	9.7	3.14	2.77	1.42	0.53	29000	10.5
6	CF 6R-A	16	M6X1	11	12	28	—*	—	9	—	3	0.5	11	3.59	3.58	2.11	1.08	25000	18.5
8	CF 8R-A	19	M8X1.25	11	12	32	—*	—	11	—	4	0.5	13	4.17	4.65	4.73	1.37	20000	28.5
10	CF 10R-A	22	M10X1.25	12	13	36	—*	—	13	—	5	1	15	5.33	6.78	5.81	1.67	17000	45
10	CF 10-1R-A	26	M10X1.25	12	13	36	—*	—	13	—	5	1	15	5.33	6.78	5.81	2.06	17000	60
12	CF 12R-A	30	M12X1.5	14	15	40	6	3	14	6	6	1.5	20	7.87	9.79	9.37	2.45	14000	95
12	CF 12-1R-A	32	M12X1.5	14	15	40	6	3	14	6	6	1.5	20	7.87	9.79	9.37	2.74	14000	105
16	CF 16R-A	35	M16X1.5	18	19.5	52	6	3	18	8	6	1.5	24	12	18.3	17.3	3.14	10000	170
18	CF 18R-A	40	M18X1.5	20	21.5	58	6	3	20	8	6	1.5	26	14.7	25.2	26.1	3.72	8500	250
20	CF 20R-A	52	M20X1.5	24	25.5	66	8	4	22	9	8	1.5	36	20.7	34.8	32.1	8.23	7000	460
20	CF 20-1R-A	47	M20X1.5	24	25.5	66	8	4	22	9	8	1.5	36	20.7	34.8	32.1	7.15	7000	385
24	CF 24R-A	62	M24X1.5	29	30.5	80	8	4	25	11	8	1.5	40	30.6	53.2	49.5	10.5	6500	815
24	CF 24-1R-A	72	M24X1.5	29	30.5	80	8	4	25	11	8	1.5	40	30.6	53.2	49.5	12.9	6500	1140
30	CF 30R-A	80	M30X1.5	35	37	100	8	4	32	15	8	2	46	45.4	87.6	73.7	14.9	5000	1870
30	CF 30-1R-A	85	M30X1.5	35	37	100	8	4	32	15	8	2	46	45.4	87.6	73.7	16.1	5000	2030
30	CF 30-2R-A	90	M30X1.5	35	37	100	8	4	32	15	8	2	46	45.4	87.6	73.7	17.3	5000	2220

**Note** The seal must be used at temperature of 80°C or below.  
Those models marked with "\*" do not have a greasing hole and cannot be replenished with grease.

**Note** ★ indicates that the dimensions in the parentheses in this row apply to stainless steel types.  
The rotation speed limit value in the table (\*\*) applies to models that have no seal and use grease lubrication. With those models using oil lubrication, up to 130% of this value is permitted. With those attached with seals, up to 70% of this value is permitted.  
THK also manufactures full-roller types (stud diameter: 6 to 30 mm).  
For the basic load ratings of full-roller types, see page p-21.

### Model number coding

**CF10 M UU R -A**

1 2 3 4 5

1 Model number 2 Made of stainless steel 3 With seal 4 Spherical outer ring  
5 With hexagon socket stud

# Model CF-V-A

Cam Follower with Hexagon Socket (Spherical Outer Ring)

# Model CF-VM-A

Stainless Steel Type

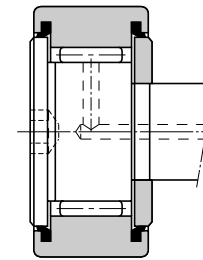
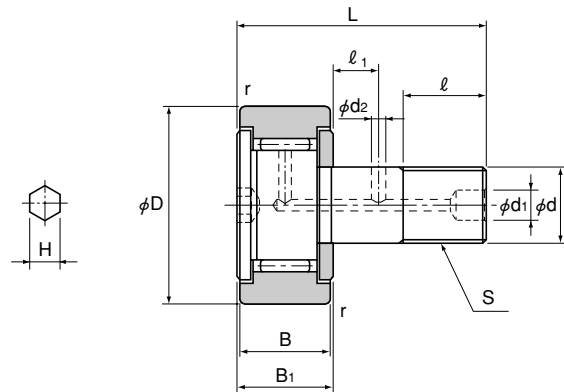

Model CF ... VUU-A

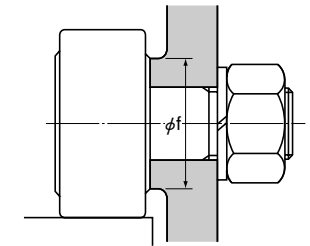

Unit: mm

Stud diameter d	Model No. Cylindrical outer ring	Major dimensions											Basic load rating		Maximum permissible load F <sub>0</sub> kN	Track load capacity kN	Rotational speed limit** min <sup>-1</sup>	Mass g	
		Outer diameter D	Thread S	Outer ring width B	B <sub>1</sub>	Overall length L	d <sub>1</sub>	d <sub>2</sub>	l	l <sub>1</sub>	H	r	Shoulder height f (Min.)	C kN					C <sub>0</sub> kN
6	CF 6V-A	16	M6X1	11	12	28	—*	—	9	—	3	0.5	11	6.94	8.5	2.11	3.43	11000	19
8	CF 8V-A	19	M8X1.25	11	12	32	—*	—	11	—	4	0.5	13	8.13	11.2	4.73	4.02	8700	29
10	CF 10V-A	22	M10X1.25	12	13	36	—*	—	13	—	5	1	15	9.42	14.3	5.81	4.7	7200	46
10	CF 10-1V-A	26	M10X1.25	12	13	36	—*	—	13	—	5	1	15	9.42	14.3	5.81	5.49	7200	61
12	CF 12V-A	30	M12X1.5	14	15	40	6	3	14	6	6	1.5	20	13.4	19.8	9.37	7.06	5800	97
12	CF 12-1V-A	32	M12X1.5	14	15	40	6	3	14	6	6	1.5	20	13.4	19.8	9.37	7.45	5800	107
16	CF 16V-A	35	M16X1.5	18	19.5	52	6	3	18	8	6	1.5	24	20.6	37.6	17.3	11.2	4500	173
18	CF 18V-A	40	M18X1.5	20	21.5	58	6	3	20	8	6	1.5	26	25.2	51.3	26.1	14.4	3800	255
20	CF 20V-A	52	M20X1.5	24	25.5	66	8	4	22	9	8	1.5	36	33.2	64.8	32.1	23.2	3400	465
20	CF 20-1V-A	47	M20X1.5	24	25.5	66	8	4	22	9	8	1.5	36	33.2	64.8	32.1	21	3400	390
24	CF 24V-A	62	M24X1.5	29	30.5	80	8	4	25	11	8	1.5	40	46.7	92.9	49.5	34.2	2900	820
24	CF 24-1V-A	72	M24X1.5	29	30.5	80	8	4	25	11	8	1.5	40	46.7	92.9	49.5	39.8	2900	1140
30	CF 30V-A	80	M30X1.5	35	37	100	8	4	32	15	8	2	46	67.6	145	73.7	52.6	2300	1870
30	CF 30-1V-A	85	M30X1.5	35	37	100	8	4	32	15	8	2	46	67.6	145	73.7	56	2300	2030
30	CF 30-2V-A	90	M30X1.5	35	37	100	8	4	32	15	8	2	46	67.6	145	73.7	59.3	2300	2220

**Note** The seal must be used at temperature of 80°C or below.  
Those models marked with "\*" do not have a greasing hole and cannot be replenished with grease.

**Note** The rotation speed limit value in the table (\*\*) applies to models that have no seal and use grease lubrication. With those models using oil lubrication, up to 130% of this value is permitted. With those attached with seals, up to 40% of this value is permitted.

### Model number coding

**CF6 V M UU -A**

1 2 3 4 5

1 Model number 2 Full-roller type 3 Made of stainless steel 4 With seal 5 With hexagon socket stud

# Model CFH-A

Cam Follower with Hexagon Socket (Cylindrical Outer Ring)

# Model CFH-M-A

Stainless Steel Type

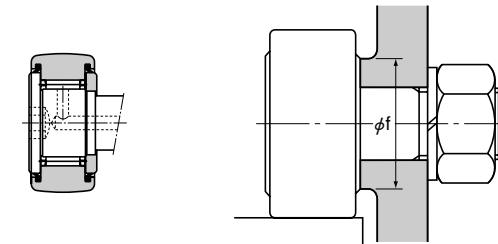
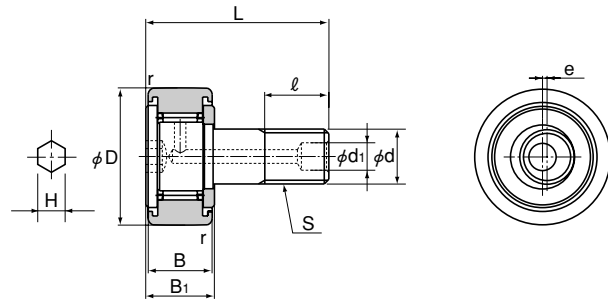

Model CFH ... UU-A

Unit: mm

Stud diameter d	Model No. Cylindrical outer ring	Major dimensions											Basic load rating		Maximum permissible load	Track load capacity	Rotational speed limit**	Mass
		Outer diameter D	Thread S	Outer ring width B	B <sub>1</sub>	Overall length L	d <sub>1</sub>	l	Run-out e	H	r	Shoulder height f (Min.)	C kN	C <sub>0</sub> kN	F <sub>0</sub> kN	kN	min <sup>-1</sup>	g
6	CFH 6-A	16	M6X1	11	12	28	—*	9	0.25	3	0.5	11	3.59	3.58	2.11	3.43	25000	18.5
8	CFH 8-A	19	M8X1.25	11	12	32	—*	11	0.25	4	0.5	13	4.17	4.65	4.73	4.02	20000	28.5
10	CFH 10-A	22	M10X1.25	12	13	36	—*	13	0.3	5	1	15	5.33	6.78	5.81	4.7	17000	45
10	CFH 10-1-A	26	M10X1.25	12	13	36	—*	13	0.3	5	1	15	5.33	6.78	5.81	5.49	17000	60
12	CFH 12-A	30	M12X1.5	14	15	40	6	14	0.4	6	1.5	20	7.87	9.79	9.37	7.06	14000	95
12	CFH 12-1-A	32	M12X1.5	14	15	40	6	14	0.4	6	1.5	20	7.87	9.79	9.37	7.45	14000	105
16	CFH 16-A	35	M16X1.5	18	19.5	52	6	18	0.5	6	1.5	24	12	18.3	17.3	11.2	10000	170
18	CFH 18-A	40	M18X1.5	20	21.5	58	6	20	0.6	6	1.5	26	14.7	25.2	26.1	14.4	8500	250
20	CFH 20-A	52	M20X1.5	24	25.5	66	8	22	0.7	8	1.5	36	20.7	34.8	32.1	23.2	7000	460
20	CFH 20-1-A	47	M20X1.5	24	25.5	66	8	22	0.7	8	1.5	36	20.7	34.8	32.1	21	7000	385
24	CFH 24-A	62	M24X1.5	29	30.5	80	8	25	0.8	8	1.5	40	30.6	53.2	49.5	34.2	6500	815
24	CFH 24-1-A	72	M24X1.5	29	30.5	80	8	25	0.8	8	1.5	40	30.6	53.2	49.5	39.8	6500	1140
30	CFH 30-A	80	M30X1.5	35	37	100	8	32	1	8	2	46	45.4	87.6	73.7	52.6	5000	1870
30	CFH 30-1-A	85	M30X1.5	35	37	100	8	32	1	8	2	46	45.4	87.6	73.7	56	5000	2030
30	CFH 30-2-A	90	M30X1.5	35	37	100	8	32	1	8	2	46	45.4	87.6	73.7	59.3	5000	2220

**Note** THK also manufactures types that have a driver groove and a greasing hole on the head (model numbers of types with a driver groove do not include symbol "A" in the end). The seal must be used at temperature of 80°C or below. Those models marked with "\*" do not have a greasing hole and cannot be replenished with grease.

**Note** The rotation speed limit value in the table (\*\*) applies to models that have no seal and use grease lubrication. With those models using oil lubrication, up to 130% of this value is permitted. With those attached with seals, up to 70% of this value is permitted. THK also manufactures full-roller types. For the basic load ratings of full-roller types, see page p-21.

### Model number coding

CFH24-1 M UU -A

1 2 3 4

1 Model number 2 Made of stainless steel 3 With seal 4 With hexagon socket stud

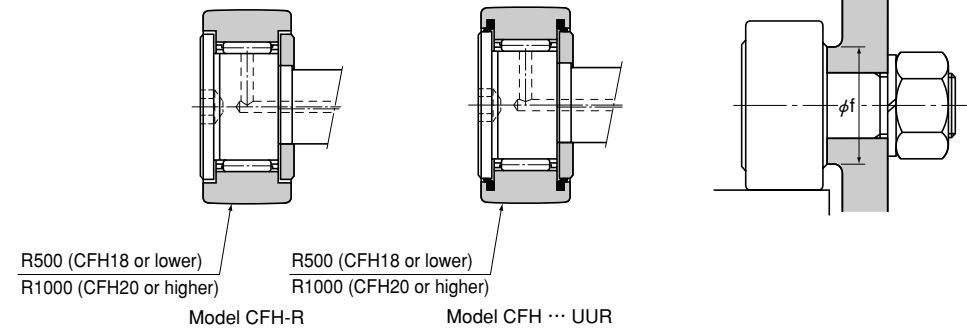
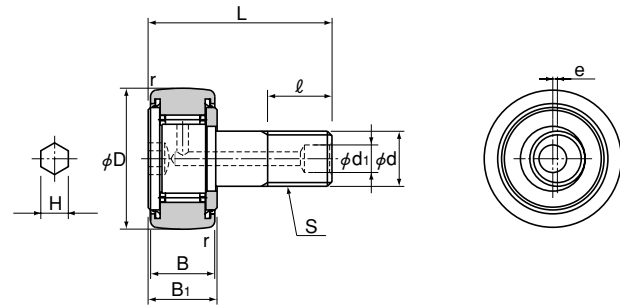

Unit: mm

Stud diameter d	Model No. Spherical outer ring	Major dimensions											Basic load rating		Maximum permissible load F <sub>0</sub> kN	Track load capacity kN	Rotational speed limit** min <sup>-1</sup>	Mass g
		Outer diameter D	Thread S	Outer ring width B	B <sub>1</sub>	Overall length L	d <sub>1</sub>	l	Run-out e	H	r	Shoulder height f (Min.)	C kN	C <sub>0</sub> kN				
6	CFH 6R-A	16	M6X1	11	12	28	—*	9	0.25	3	0.5	11	3.59	3.58	2.11	1.08	25000	18.5
8	CFH 8R-A	19	M8X1.25	11	12	32	—*	11	0.25	4	0.5	13	4.17	4.65	4.73	1.37	20000	28.5
10	CFH 10R-A	22	M10X1.25	12	13	36	—*	13	0.3	5	1	15	5.33	6.78	5.81	1.67	17000	45
10	CFH 10-1R-A	26	M10X1.25	12	13	36	—*	13	0.3	5	1	15	5.33	6.78	5.81	2.06	17000	60
12	CFH 12R-A	30	M12X1.5	14	15	40	6	14	0.4	6	1.5	20	7.87	9.79	9.37	2.45	14000	95
12	CFH 12-1R-A	32	M12X1.5	14	15	40	6	14	0.4	6	1.5	20	7.87	9.79	9.37	2.74	14000	105
16	CFH 16R-A	35	M16X1.5	18	19.5	52	6	18	0.5	6	1.5	24	12	18.3	17.3	3.14	10000	170
18	CFH 18R-A	40	M18X1.5	20	21.5	58	6	20	0.6	6	1.5	26	14.7	25.2	26.1	3.72	8500	250
20	CFH 20R-A	52	M20X1.5	24	25.5	66	8	22	0.7	8	1.5	36	20.7	34.8	32.1	8.23	7000	460
20	CFH 20-1R-A	47	M20X1.5	24	25.5	66	8	22	0.7	8	1.5	36	20.7	34.8	32.1	7.15	7000	385
24	CFH 24R-A	62	M24X1.5	29	30.5	80	8	25	0.8	8	1.5	40	30.6	53.2	49.5	10.5	6500	815
24	CFH 24-1R-A	72	M24X1.5	29	30.5	80	8	25	0.8	8	1.5	40	30.6	53.2	49.5	12.9	6500	1140
30	CFH 30R-A	80	M30X1.5	35	37	100	8	32	1	8	2	46	45.4	87.6	73.7	14.9	5000	1870
30	CFH 30-1R-A	85	M30X1.5	35	37	100	8	32	1	8	2	46	45.4	87.6	73.7	16.1	5000	2030
30	CFH 30-2R-A	90	M30X1.5	35	37	100	8	32	1	8	2	46	45.4	87.6	73.7	17.3	5000	2220

**Note** THK also manufactures types that have a driver groove and a greasing hole on the head (model numbers of types with a driver groove do not include symbol "A" in the end). The seal must be used at temperature of 80°C or below. Those models marked with "\*" do not have a greasing hole and cannot be replenished with grease.

**Note** The rotation speed limit value in the table (\*\*) applies to models that have no seal and use grease lubrication. With those models using oil lubrication, up to 130% of this value is permitted. With those attached with seals, up to 70% of this value is permitted. THK also manufactures full-roller types. For the basic load ratings of full-roller types, see page p-21.

Model number coding

CFH12 UU R -A

1 2 3 4

1 Model number 2 With seal 3 Spherical outer ring 4 With hexagon socket stud

# Model CFN-R-A

Cam Follower Containing Thrust Balls

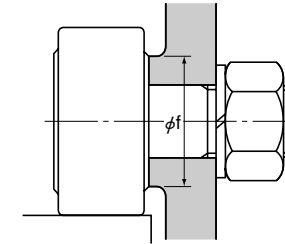
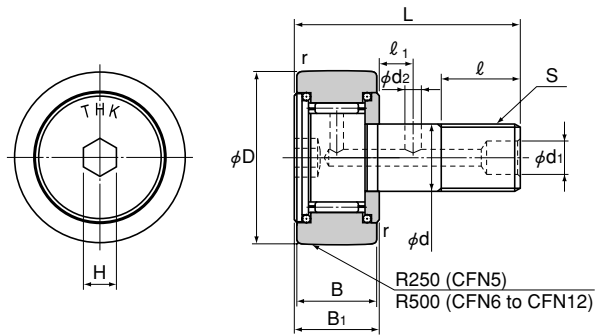

Unit: mm

Stud diameter d	Model No. Spherical outer ring	Major dimensions													Basic load rating		Permissible thrust load N	Maximum per- missible load F <sub>o</sub> kN	Track load capacity kN	Rotational speed limit** min <sup>-1</sup>	Mass g
		Outer diameter D	Thread S	Outer ring width B	B <sub>1</sub>	Overall length L	d <sub>1</sub>	d <sub>2</sub>	l	l <sub>1</sub>	H	r	Shoulder height f (Min.)	C kN	C <sub>o</sub> kN						
5	CFN 5R-A	13	M5×0.8	9	10	23	—*	—*	7.5	—	3	0.5	10	3.14	2.77	160	1.42	0.53	29000	10.5	
6	CFN 6R-A	16	M6×1	11	12	28	—*	—*	9	—	3	0.5	12	3.59	3.58	250	2.11	1.08	25000	18.5	
8	CFN 8R-A	19	M8×1.25	11	12	32	—*	—*	11	—	4	0.5	14	4.17	4.65	290	4.73	1.37	20000	28.5	
10	CFN 10R-A	22	M10×1.25	12	13	36	—*	—*	13	—	5	1	16.5	5.33	6.78	400	5.81	1.67	17000	45	
12	CFN 12R-A	30	M12×1.5	14	15	40	6	3	14	6	6	1.5	21.5	7.87	9.79	680	9.37	2.45	14000	95	

**Note** Those models marked with "\*" do not have a greasing hole and cannot be replenished with grease.

**Note** The rotation speed limit value in the table (\*\*) applies to models using grease lubrication. With those models using oil lubrication, up to 130% of this value is permitted.

## Model number coding

**CFN12 R -A**

1 2 3

1 Model number 2 Spherical outer ring 3 With hexagon socket stud

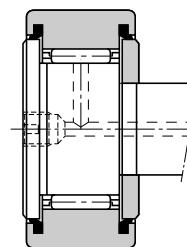
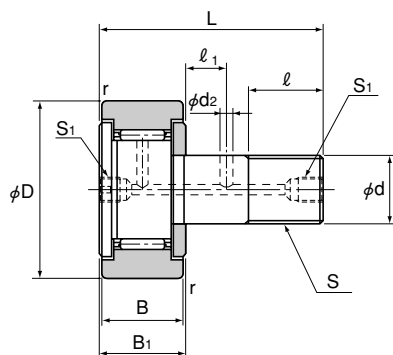

Model CFT ... UU

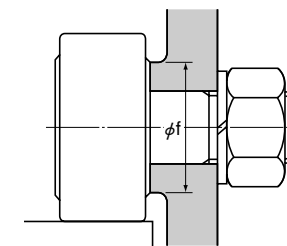

Unit: mm

Stud diameter d	Model No. Cylindrical outer ring	Major dimensions											Basic load rating		Maximum permissible load	Track load capacity	Rotational speed limit**	Mass
		Outer diameter D	Thread S	Outer ring width B	B <sub>1</sub>	Overall length L	S <sub>1</sub>	d <sub>2</sub>	l	l <sub>1</sub>	r	Shoulder height f (Min.)	C kN	C <sub>0</sub> kN	F <sub>0</sub> kN	kN	min <sup>-1</sup>	g
6	CFT 6	16	M6×1	11	12	28	M6×0.75 *	—	9	—	0.5	11	3.59	3.58	2.11	3.43	25000	18.5
8	CFT 8	19	M8×1.25	11	12	32	M6×0.75 *	—	11	—	0.5	13	4.17	4.65	4.73	4.02	20000	28.5
10	CFT 10	22	M10×1.25	12	13	36	M6×0.75 *	—	13	—	1	15	5.33	6.78	5.81	4.7	17000	45
10	CFT 10-1	26	M10×1.25	12	13	36	M6×0.75 *	—	13	—	1	15	5.33	6.78	5.81	5.49	17000	60
12	CFT 12	30	M12×1.5	14	15	40	M6×0.75	3	14	6	1.5	20	7.87	9.79	9.37	7.06	14000	95
12	CFT 12-1	32	M12×1.5	14	15	40	M6×0.75	3	14	6	1.5	20	7.87	9.79	9.37	7.45	14000	105
16	CFT 16	35	M16×1.5	18	19.5	52	PT 1/8	3	18	8	1.5	24	12	18.3	17.3	11.2	10000	170
18	CFT 18	40	M18×1.5	20	21.5	58	PT 1/8	3	20	8	1.5	26	14.7	25.2	26.1	14.4	8500	250
20	CFT 20	52	M20×1.5	24	25.5	66	PT 1/8	4	22	9	1.5	36	20.7	34.8	32.1	23.2	7000	460
20	CFT 20-1	47	M20×1.5	24	25.5	66	PT 1/8	4	22	9	1.5	36	20.7	34.8	32.1	21	7000	385
24	CFT 24	62	M24×1.5	29	30.5	80	PT 1/8	4	25	11	1.5	40	30.6	53.2	49.5	34.2	6500	815
24	CFT 24-1	72	M24×1.5	29	30.5	80	PT 1/8	4	25	11	1.5	40	30.6	53.2	49.5	39.8	6500	1140
30	CFT 30	80	M30×1.5	35	37	100	PT 1/8	4	32	15	2	46	45.4	87.6	73.7	52.6	5000	1870
30	CFT 30-1	85	M30×1.5	35	37	100	PT 1/8	4	32	15	2	46	45.4	87.6	73.7	56	5000	2030
30	CFT 30-2	90	M30×1.5	35	37	100	PT 1/8	4	32	15	2	46	45.4	87.6	73.7	59.3	5000	2220

**Note** The seal must be used at temperature of 80°C or below.  
Those models marked with "\*" have a greasing hole only on the head.

**Note** The rotation speed limit value in the table (\*\*) applies to models that have no seal and use grease lubrication. With those models using oil lubrication, up to 130% of this value is permitted. With those attached with seals, up to 70% of this value is permitted.  
THK also manufactures full-roller types.  
For the basic load ratings of full-roller types, see page p-21.

Model number coding



1 Model number 2 Made of stainless steel 3 With seal

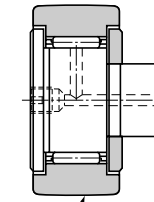
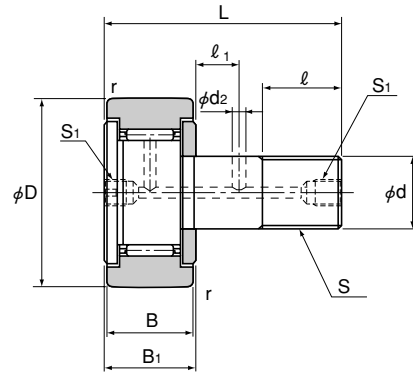

R500 (CFT18 or lower)  
R1000 (CFT20 or higher)

Model CFT-R

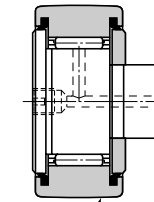

R500 (CFT18 or lower)  
R1000 (CFT20 or higher)

Model CFT ... UUR

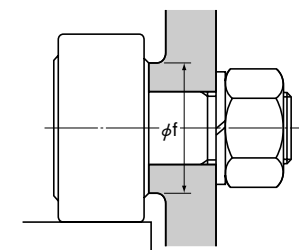

Unit: mm

Stud diameter d	Model No. Spherical outer ring	Outer diameter D	Thread S	Outer ring width B	B <sub>1</sub>	Overall length L	Major dimensions						Basic load rating		Maximum permissible load	Track load capacity	Rotational speed limit**	Mass
							S <sub>1</sub>	d <sub>2</sub>	l	l <sub>1</sub>	r	Shoulder height f (Min.)	C kN	C <sub>0</sub> kN	F <sub>0</sub> kN	kN	min <sup>-1</sup>	g
6	CFT 6R	16	M6×1	11	12	28	M6×0.75 *	—	9	—	0.5	11	3.59	3.58	2.11	1.08	25000	18.5
8	CFT 8R	19	M8×1.25	11	12	32	M6×0.75 *	—	11	—	0.5	13	4.17	4.65	4.73	1.37	20000	28.5
10	CFT 10R	22	M10×1.25	12	13	36	M6×0.75 *	—	13	—	1	15	5.33	6.78	5.81	1.67	17000	45
10	CFT 10-1R	26	M10×1.25	12	13	36	M6×0.75 *	—	13	—	1	15	5.33	6.78	5.81	2.06	17000	60
12	CFT 12R	30	M12×1.5	14	15	40	M6×0.75	3	14	6	1.5	20	7.87	9.79	9.37	2.45	14000	95
12	CFT 12-1R	32	M12×1.5	14	15	40	M6×0.75	3	14	6	1.5	20	7.87	9.79	9.37	2.74	14000	105
16	CFT 16R	35	M16×1.5	18	19.5	52	PT 1/8	3	18	8	1.5	24	12	18.3	17.3	3.14	10000	170
18	CFT 18R	40	M18×1.5	20	21.5	58	PT 1/8	3	20	8	1.5	26	14.7	25.2	26.1	3.72	8500	250
20	CFT 20R	52	M20×1.5	24	25.5	66	PT 1/8	4	22	9	1.5	36	20.7	34.8	32.1	8.23	7000	460
20	CFT 20-1R	47	M20×1.5	24	25.5	66	PT 1/8	4	22	9	1.5	36	20.7	34.8	32.1	7.15	7000	385
24	CFT 24R	62	M24×1.5	29	30.5	80	PT 1/8	4	25	11	1.5	40	30.6	53.2	49.5	10.5	6500	815
24	CFT 24-1R	72	M24×1.5	29	30.5	80	PT 1/8	4	25	11	1.5	40	30.6	53.2	49.5	12.9	6500	1140
30	CFT 30R	80	M30×1.5	35	37	100	PT 1/8	4	32	15	2	46	45.4	87.6	73.7	14.9	5000	1870
30	CFT 30-1R	85	M30×1.5	35	37	100	PT 1/8	4	32	15	2	46	45.4	87.6	73.7	16.1	5000	2030
30	CFT 30-2R	90	M30×1.5	35	37	100	PT 1/8	4	32	15	2	46	45.4	87.6	73.7	17.3	5000	2220

**Note** The seal must be used at temperature of 80°C or below.  
Those models marked with "\*" have a greasing hole only on the head.

**Note** The rotation speed limit value in the table (\*\*) applies to models that have no seal and use grease lubrication. With those models using oil lubrication, up to 130% of this value is permitted. With those attached with seals, up to 70% of this value is permitted.  
THK also manufactures full-roller types.  
For the basic load ratings of full-roller types, see page p-21.

Model number coding

CFT30-1 M UU R



1 Model number 2 Made of stainless steel 3 With seal 4 Spherical outer ring