

Electrak E150

12 and 24 VDC
110, 225, 450 lb. load capacities



Features

- Low cost
- Quiet operation
- Optional adjustable limit switches
- IP-56 rated for outdoor use
- Durable, lightweight, plastic housing
- Available DC voltages: 12 or 24
- Estimated life at rated load is 40,000 cycles minimum

Compact, low cost plastic housing

The Electrak 150 is the first of a new series of low priced, quiet actuators with different load and speed ranges.

There are a number of design features that make this actuator different. The optional limit switches are designed to operate with fewer parts. The plastic cover is designed to be recyclable. The actuator has a breather tube in the wiring harness to allow the actuator to operate without drawing water through the seals on the cover tube. The colors are molded into the plastic to both eliminate the need for paint and touchup of scratches. The anodized aluminum cover tube is corrosion resistant and also hides scratches. The extension tube is stainless steel and the front and rear adapters are zinc die castings for corrosion resistance. All of the thrust is resolved through the screw with the plastic housing providing environmental protection but carrying no load. The entire actuator has been created for ease of installation, quiet operation, no maintenance, light weight, and low cost.

Typical applications

- Automatic security gate positioning
- Raise/lower the deck on riding mowers
- Position ladders, vents, discharge chutes on combines
- Tilt/recline on powered wheelchairs
- Position ergonomic tables, chairs
- Position diverters on conveyors
- Position jigs in flexible assembly operations

Controls

DF14 controls operate one or two Electrak 150 actuators. Available with one or two 24 VDC outputs with a handset to manually control bi-directional motion on each of the control outputs. Each actuator can be operated independently and sequentially but not simultaneously. It has quick disconnect sockets for the handset, cable adapters for 5, 10 and 15 foot lengths to connect to each actuator. See page D-47.

Dimensions

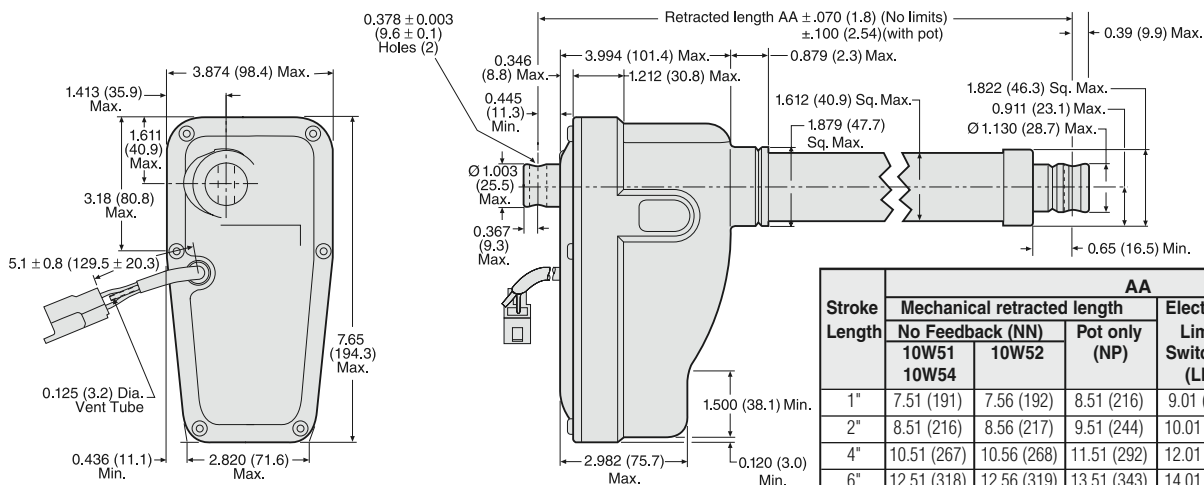

Dimensions are for standard units.

Stroke Length	AA					Wt. lbs.
	Mechanical retracted length			Electrical Limit Switches (LN)	Pot and Limit Switches (LP)	
	No Feedback (NN)	Pot only (NP)				
	10W51	10W52				
1"	7.51 (191)	7.56 (192)	8.51 (216)	9.01 (229)	9.01 (229)	4.79
2"	8.51 (216)	8.56 (217)	9.51 (244)	10.01 (254)	10.01 (254)	4.89
4"	10.51 (267)	10.56 (268)	11.51 (292)	12.01 (305)	12.01 (305)	5.18
6"	12.51 (318)	12.56 (319)	13.51 (343)	14.01 (356)	14.01 (356)	5.46
8"	14.51 (369)	14.56 (370)	15.51 (394)	16.01 (407)	16.01 (407)	5.75
10"	16.51 (419)	16.56 (421)	17.51 (445)	18.01 (458)	18.01 (458)	6.03
12"	18.51 (470)	18.56 (471)	19.51 (496)	20.01 (508)	20.01 (508)	6.32
14"	20.51 (521)	20.56 (522)	21.51 (546)	22.01 (559)	22.01 (559)	6.60
16"	22.51 (572)	22.56 (573)	N/A	24.01 (610)	N/A	6.88

Specifications

	DF12-10W51-XXX	DF12-10W52-XXX	DF12-10W54-XX
Dynamic load	450 lbs. max.	225 lbs. max.	110 lbs. max.
Static Load	900 lbs. max.	400 lbs. max.	330 lbs. max.
Speed	.75"/sec @ no load .4"/sec @ 112 lbs.	1.40"/sec @ no load .8"/sec @ 60 lbs.	2.8"/sec @ no load 1.6"/sec @ 30 lbs.
End play	0.036" max less clevis	0.036" max less clevis	0.046" max less clevis
Restraining torque	Restrained internally		
Input voltage	12, 24 VDC (36 VDC*, 115 VAC*)		
Amperage (12 VDC)	2.5-13 (50 amp @ stall)		
End of stroke	Stall, optional limit switches		
Thermal protection	Internal motor breaker		
Lead wires	16 AWG PVC 800		
Connectors	Packard Electric Pack-Con		
Power switch	Optional DPDT		
Temperature	-30° to +150° F (-34° to 66° C)		
Environment	IP-56 outdoor use		
Duty cycle	25% @ 70° F		
Anti-rotation	Tube can rotate max. of 7°		

* consult customer service

Performance Curves

DF 12 Motor Curve

Input voltage: 10–16 volts

Nominal performance at 12 VDC and 70°F (21°C)

Amperage: 13 amps max. at rated dynamic load and 70°F (21°C) ambient

Max. amp draw at stall: 50 amps

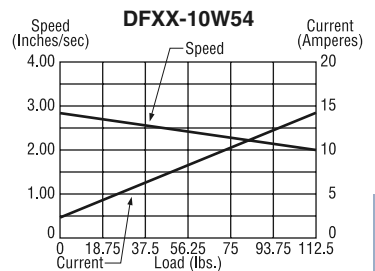
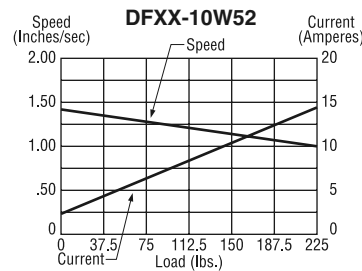
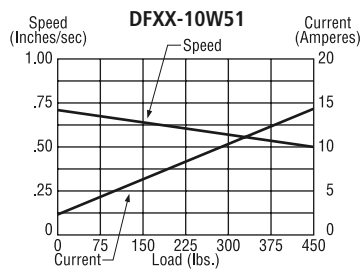

DF 24 Motor Curve

Input voltage: 20–28 volts

Nominal performance at 24 VDC and 70°F (21°C)

Amperage: 6.5 amps max. at rated dynamic load and 70°F (21°C) ambient

Max. amp draw at stall: 25 amps

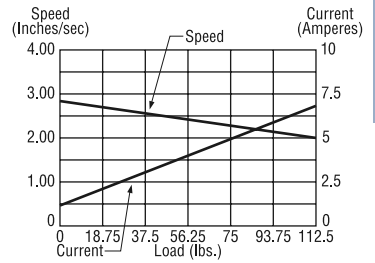
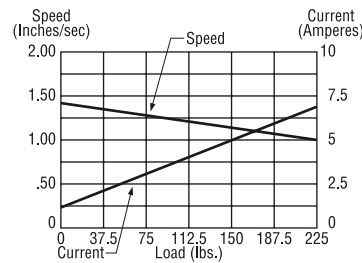
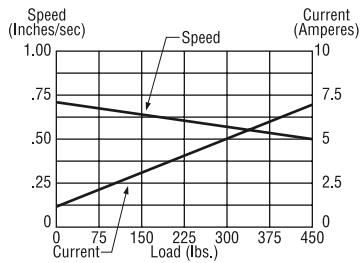

How To Order

D F X X - 1 0 W 5 X - X X X X X X X

Motor Type: D = DC

Actuator Type: F = E150

Motor Voltage: 12, 24, 36

Gear Ratio: 10:1

Screw Type: W = Worm

Screw Diameter: (tenths of an inch)

Screw Lead: (tenths of an inch) 1,2,4

Stroke Length: Inches

Other Options: N = None

Front Mounting: H = Crosshole

Rear Mounting: H = Crossholes are shown above,
M = Both front and rear rotated 90°

Feedback: N = None, P = Potentiometer

Limit Switches: L = Limits, N = None

Example: DF12-10W51-04LNHHN