



General purpose DC actuator

Electrak 10 models incorporate a ball bearing screw drive system for applications requiring maximum load capacity. A specially designed anti-back driving brake holds tension or compression loads in position when the actuator is not in use. This holding brake activates automatically when the actuator is turned off and will continue to hold the load in position without power consumption, until the actuator is started.

Design features such as strong alloy housing, reinforced end plugs and rugged spur gearing are standard with the Electrak 10 series.

The Electrak 10 series provides as much as 1500* pounds of force from a 12" long package. Twelve inches of linear travel is available from an overall package length of just 20 inches.

Features

- Clevis mounting
- Protective seal
- Sturdy steel cover tube
- Ball bearing screw drive systems
- Overload clutch
- 4, 8 or 12" stroke lengths
- Stainless steel extension tube
- Rugged spur gearing
- 12 or 24 VDC
- Lifetime lubrication of gears
- Thermal overload protection

Typical Applications

- Heavy duty platform lifts
- Bench clamps
- Door control
- Battery powered applications

Control

The MCS-205 control provides 24 VDC output power for use with the Electrak 10 actuator. Membrane switches, dynamic braking and other features make the control and actuator an efficient, reliable system. The MCS-2015 control can also be used to operate this actuator. See page D-47.

Dimensions

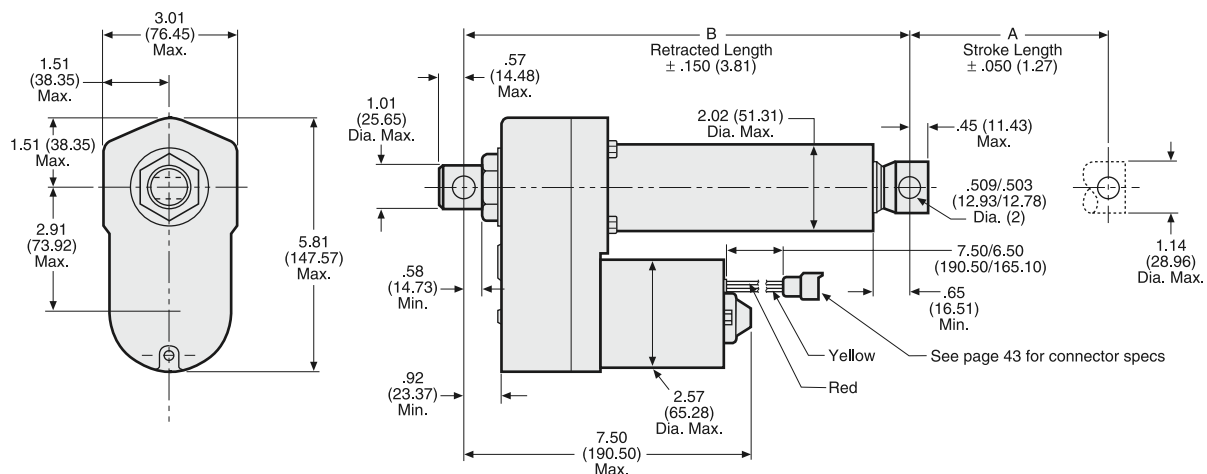

Specifications

Input	12 or 24 VDC
Load capacities	500, 1000 or 1500* lbs. maximum, depending on model
Stroke lengths	4, 8, 12 inches (also 18 and 24 inches)*
Current draw	7 amps at 24 VDC – 1000 lb. capacity at full load 14 amps at 12 VDC – 1000 lb. capacity at full load 14 amps at 24 VDC – 500 lb. capacity at full load 28 amps at 12 VDC – 500 lb. capacity at full load
Duty cycle	25% "on time" at rated load per cycle (77° F)
Motor protection	Automatic reset thermal overload in motor winding
Overload Protection	Ball detent overload clutch
Temperature range	-15° F to 150° F
Environment protection	96 hour salt spray tested
Drive	Ball bearing screw
Housing	Zinc
Lead wires	14 gauge
Mounting	Clevis Mounting only
Capacitor	Included in MCS-2041 or MCS-2042 or must be ordered separately
Restraining torque	100 in. lb.
End Play	.040 in. max.
Static Load	3000 lbs.
Wiring diagram	See page D-59

*Consult customer service

Model Numbers – use when ordering

Stroke Length*	Voltage	Load Capacity		A	B	Weight lbs.
		500 lbs.	1000 lbs.			
4	12 VDC	D12-05B5-04	D12-20B5-04	4.00	11.89	11.30
	24 VDC	D24-05B5-04	D24-20B5-04	(101.60)	(302.21)	11.30
8	12 VDC	D12-05B5-08	D12-20B5-08	8.00	15.89	12.02
	24 VDC	D24-05B5-08	D24-20B5-08	(203.20)	(403.81)	12.02
12	12 VDC	D12-05B5-12	D12-20B5-12	12.00	19.89	12.74
	24 VDC	D24-05B5-12	D24-20B5-12	(304.80)	(505.41)	12.74

*For longer stroke versions or models including other options – contact the factory.

Performance Curves

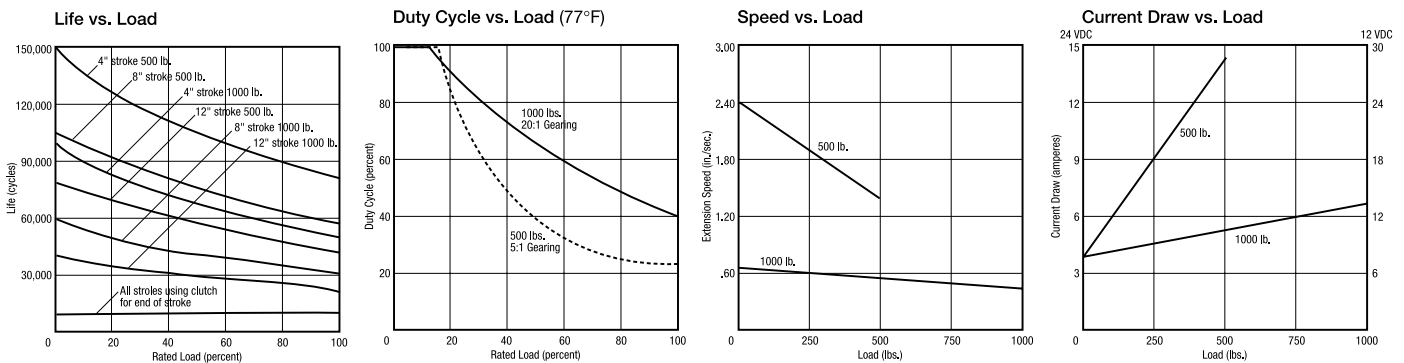

How To Order

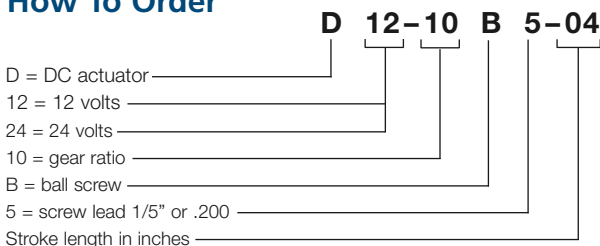

©2003 Danaher Motion. Printed in the U.S.A. The specifications in this publication are believed to be accurate and reliable. However, it is the responsibility of the product user to determine the suitability of Thomson products for a specific application. While defective products will be replaced without charge if promptly returned, no liability is assumed beyond such replacement.