

LoadMaster 80

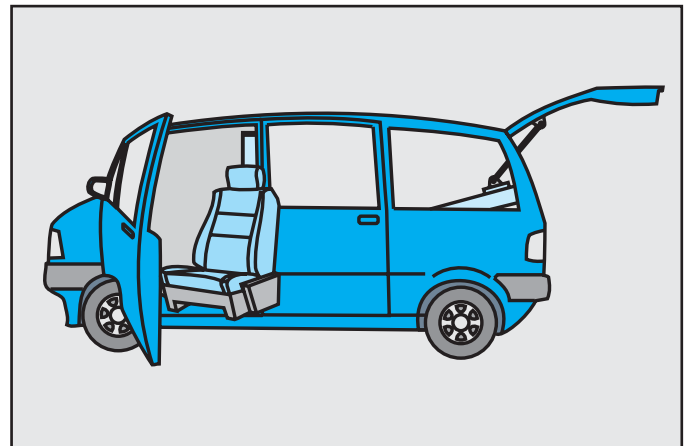

- Rodless actuator
- Two versions, for horizontal or vertical operation
- Rigid self supporting aluminium profile
- Quiet operation for indoor domestic or medical use
- Trapezoidal or ball screw drive
- Spring loaded soft stop at end of stroke
- Stroke up to 1500 mm (longer possible upon request)
- Speed up to 110 mm/s
- Load up to 2000 N
- Options such as hand wind, spline safety function and alternative motor positions.



Handicap adaptation of vehicles

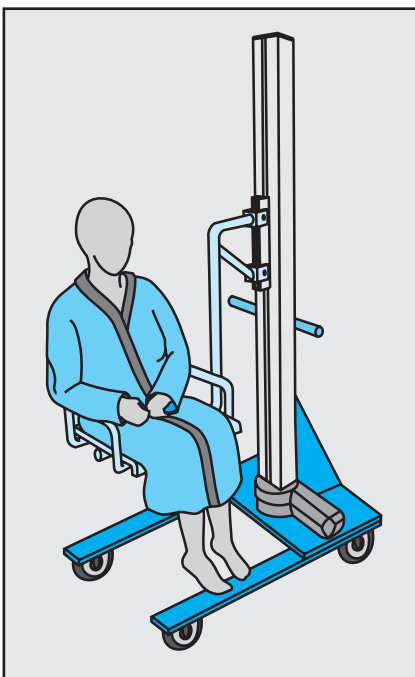

Lifting aids for disabled

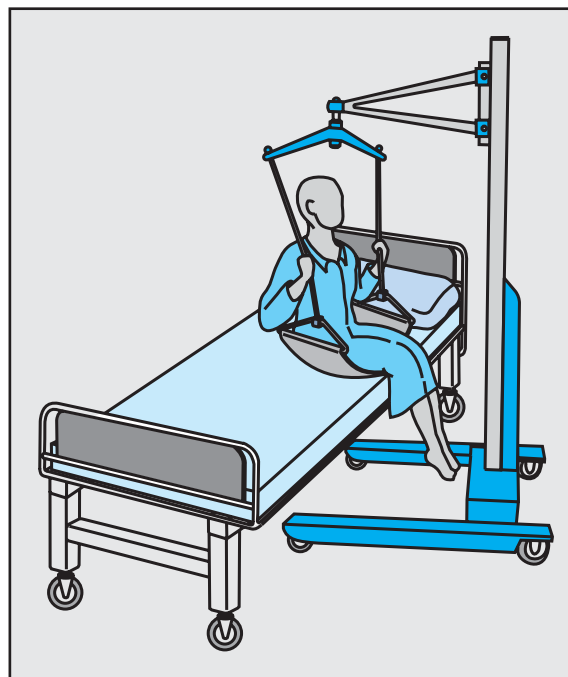

Patient lifts

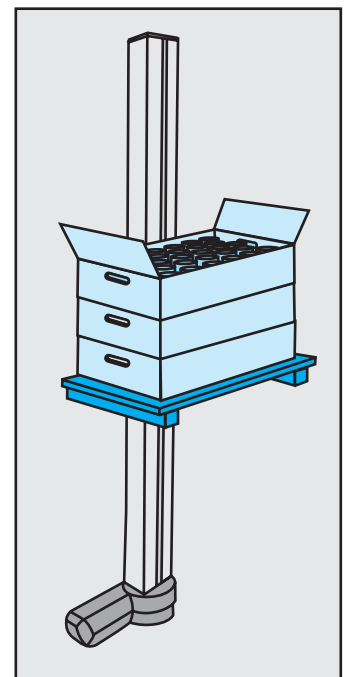

Loading and unloading stations

LoadMaster 80 – version for vertical operation

Technical data

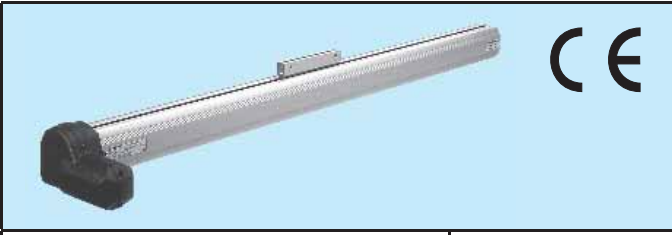
	
Available input voltages [Vdc]	12, 24
Available screw types	Trapezoidal or Ball
Max. load F_a [N]	
DT •• – T68M ••••• V(F)	650
DT •• – B61M ••••• V(F)	1000
DT •• – B62M ••••• V(F)	450
DT •• – B65M ••••• V(F)	2000
Max. load torque M_a [Nm]	
DT •• – T68M ••••• V(F)	250
DT •• – B61M ••••• V(F)	400
DT •• – B62M ••••• V(F)	180
DT •• – B65M ••••• V(F)	750
Min. / max. standard stroke [mm]	500 / 1500
Duty cycle @ 20° C [%]	15
Max. operation time [s]	120
Temperature limits at operation [°C]	-0 to + 40
Protection degree	
With motor enclosure	IP44
Without motor enclosure	IP33
Weight [kg]	$L \times 5,7 + 2,8$
Wire cross section [mm ²]	1,5
Cable length [mm]	
Models with motor enclosure	2000
Models without motor enclosure	cable clips on motor
Connector included	
Models with motor enclosure	yes
Models without motor enclosure	no

Performance table

Model	Maximum load F_a [N]	Speed @ min. load [mm/s]	Speed @ max. load [mm/s]
DT12–T68M ••••• V(F)	650	44	29
DT24–T68M ••••• V(F)	650	44	35
DT12–B61M ••••• V(F)	1000	55	37
DT24–B61M ••••• V(F)	1000	55	43
DT12–B62M ••••• V(F)	450	110	67
DT24–B62M ••••• V(F)	450	110	83
DT12–B65M ••••• V(F)	2000	28	19
DT24–B65M ••••• V(F)	2000	28	22

Features

- Rodless actuator for vertical operation
- Durable, corrosion free and lightweight
- Stable self supporting extruded aluminium profile
- Easy T-slot mounting
- Trapezoidal or ball screw drive
- Holds load at stand still (self locking)
- Spring loaded soft stop at end of stroke
- Safety nut on all ball screw models
- Motor with auto reset thermal overload protection
- Can operate in a large temperature range
- Accepts large input voltage variations
- IP44 (enclosed version) or IP33
- Maintenance free

Options

- Hand wind
- Alternative motor position
- Spline safety function

Forces

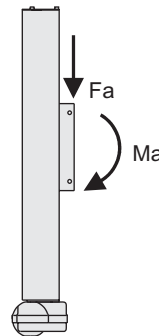

Motor positions

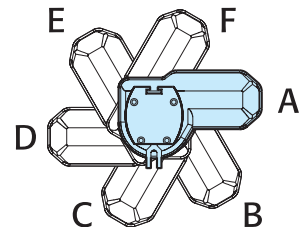

Standard strokes

Ordering stroke [cm]	Actual stroke S [mm]
50	500
60	600
70	700
80	800
90	900
100	1000
110	1100
120	1200
130	1300
140	1400
150	1500

T-slot bolt kit

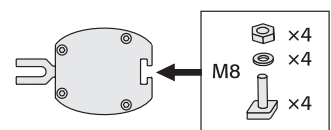

P/n D680 507

LoadMaster 80 – version for vertical operation

Dimensions

Vertical models

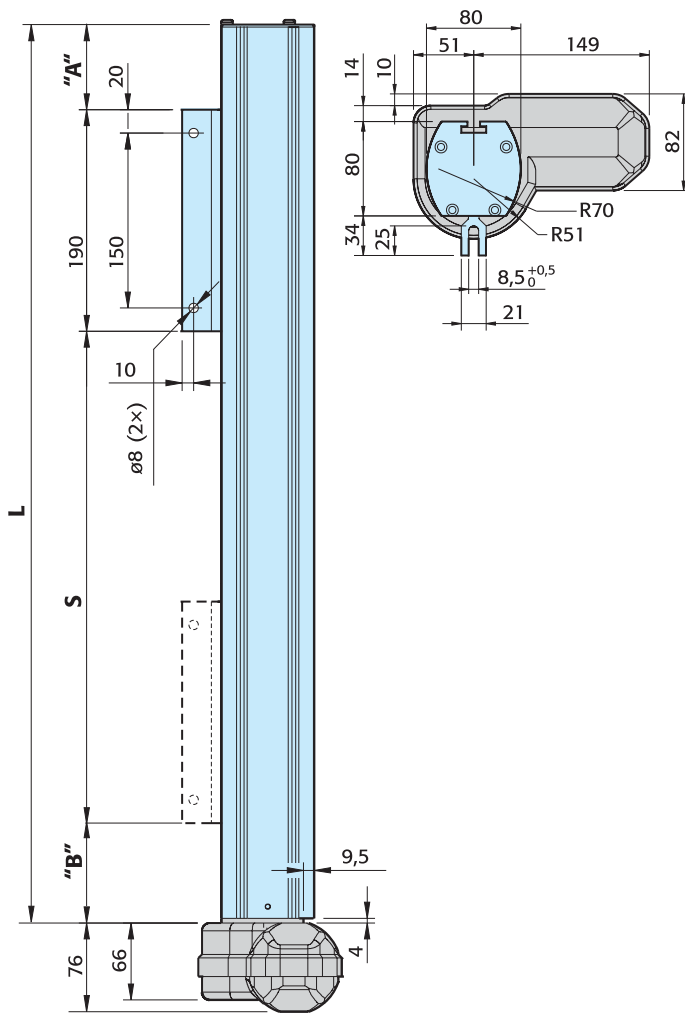

Model	"A"	"B"
DT •• – B65M ••••• V •	53	97
DT •• – B62M ••••• V •	53	120
DT •• – B61M ••••• V •	53	120
DT •• – T68M ••••• V •	50	88

Model	"A"	"B"
DT •• – B65M ••••• F •	53	126
DT •• – B62M ••••• F •	53	144
DT •• – B61M ••••• F •	53	144
DT •• – T68M ••••• F •	50	92

Performance diagrams

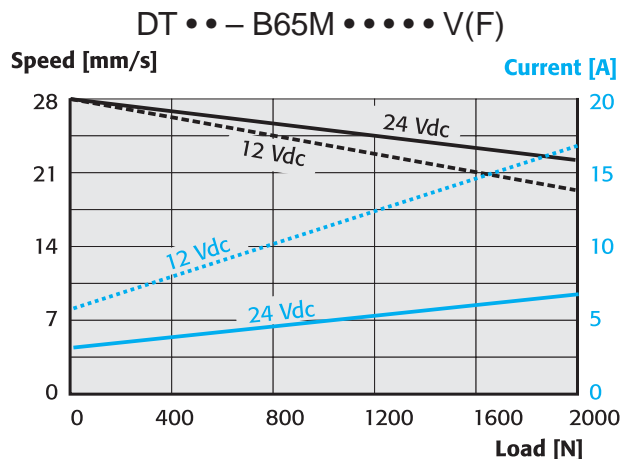
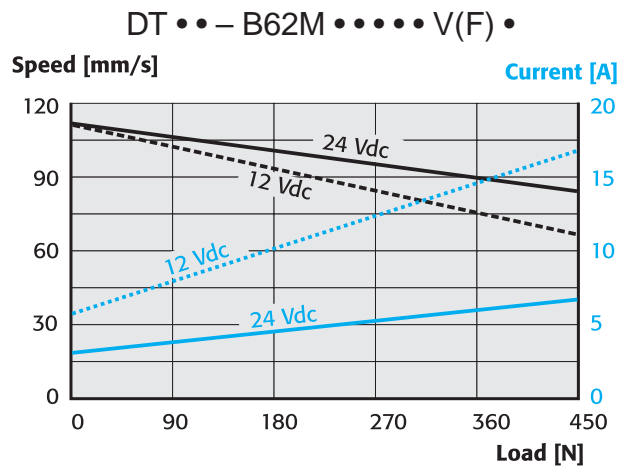
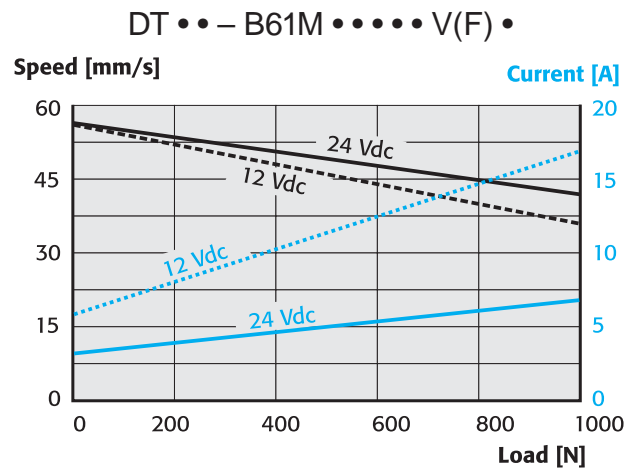
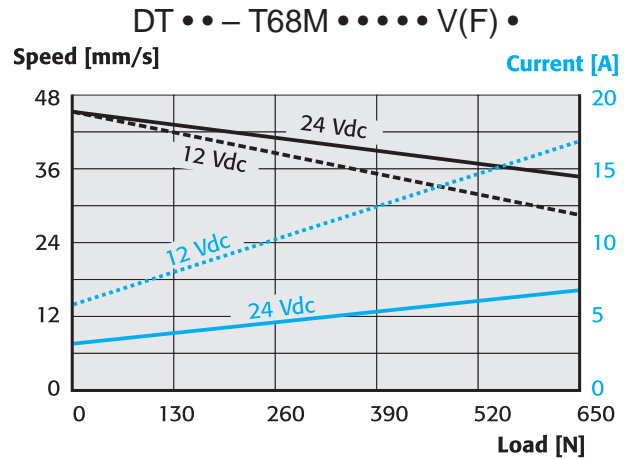

LoadMaster 80 – version for horizontal operation

Technical data

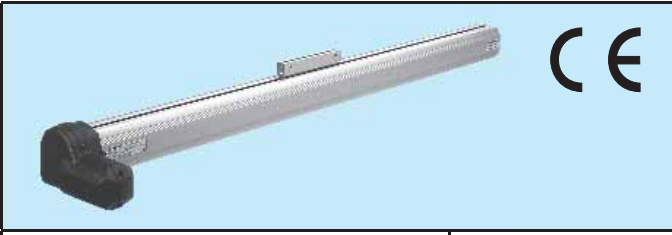
	
Available input voltages [Vdc]	12, 24
Available screw types	Trapezoidal or Ball
Max. load Fb [N]	2000
Max. load torque Mb [Nm]	
DT ••– T68M ••••• H	250
DT ••– B61M ••••• H	400
DT ••– B62M ••••• H	180
DT ••– B65M ••••• H	750
Min. / max. standard stroke [mm]	500 / 1500
Duty cycle @ 20° C [%]	15
Max. operation time [s]	120
Temperature limits at operation [°C]	-0 to + 40
Protection degree	
With motor enclosure	IP44
Without motor enclosure	IP33
Weight [kg]	L x 5,7 + 2,8
Wire cross section [mm ²]	1,5
Cable length [mm]	
Models with motor enclosure	2000
Models without motor enclosure	cable clips on motor
Connector included	
Models with motor enclosure	yes
Models without motor enclosure	no

Features

- Rodless actuator for horizontal operation
- Durable, corrosion free and lightweight
- Stable self supporting extruded aluminium profile
- Easy T-slot mounting
- Trapezoidal or ball screw drive
- Spring loaded soft stop at end of stroke
- Safety nut on all ball screw models
- Motor with auto reset thermal overload protection
- Can operate in a large temperature range
- Accepts large input voltage variations
- IP44 (enclosed version) or IP33
- Maintenance free

Options

- Hand wind
- Alternative motor position

Forces

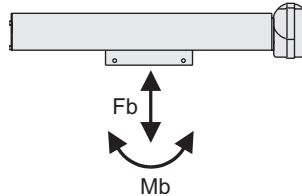

Motor positions

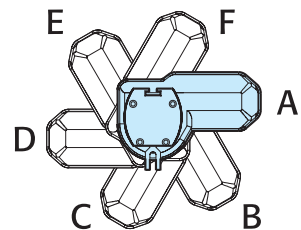

Performance table

Model	Maximum load Fb [N]	Speed @ min. load [mm/s]	Speed @ max. load [mm/s]
DT12–T68M ••••• H	2000	44	37
DT24–T68M ••••• H	2000	44	37
DT12–B61M ••••• H	2000	55	50
DT24–B61M ••••• H	2000	55	50
DT12–B62M ••••• H	2000	110	73
DT24–B62M ••••• H	2000	110	87
DT12–B65M ••••• H	2000	28	28
DT24–B65M ••••• H	2000	28	28

Standard strokes

Ordering stroke [cm]	Actual stroke S [mm]
50	500
60	600
70	700
80	800
90	900
100	1000
110	1100
120	1200
130	1300
140	1400
150	1500

T-slot bolt kit

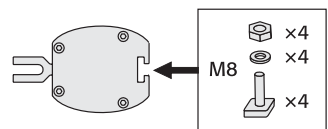

P/n D680 507

LoadMaster 80 – version for horizontal operation

Dimensions

Horizontal models

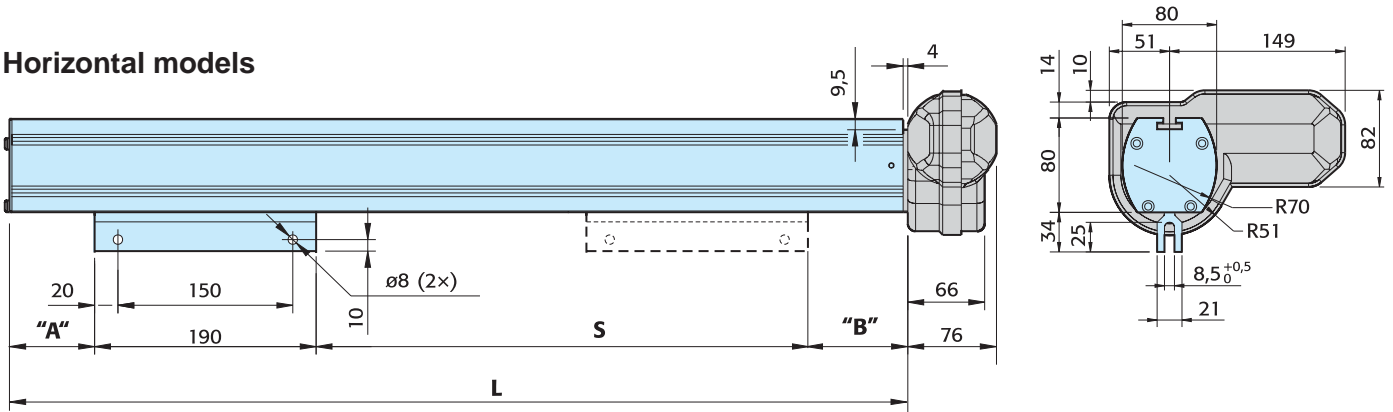

Deflection of profile

Model	"A"	"B"
DT •• – B65M ••••• H •	79,0	77,0
DT •• – B62M ••••• H •	102,0	77,0
DT •• – B61M ••••• H •	102,0	77,0
DT •• – T68M ••••• H •	55,0	76,0

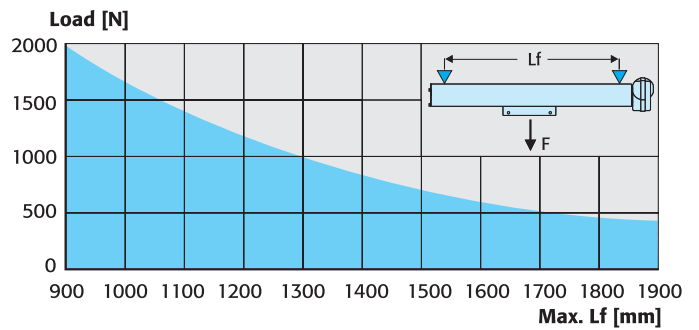

Performance diagrams

DT •• – T68M ••••• H •

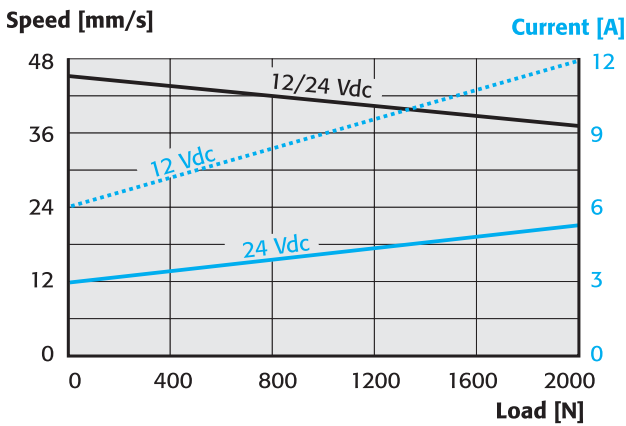

DT •• – B61M ••••• H •

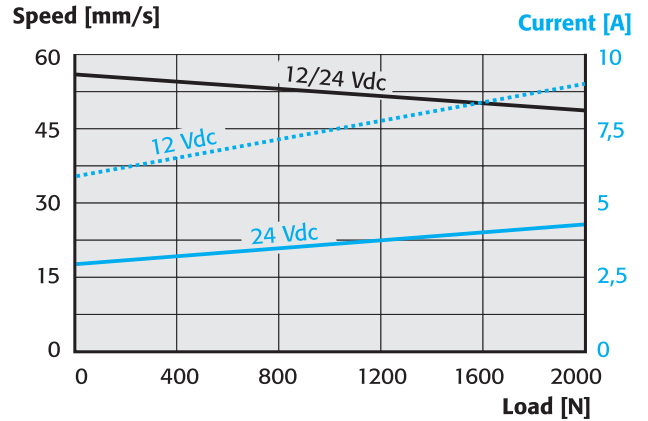

DT •• – B62M ••••• H •

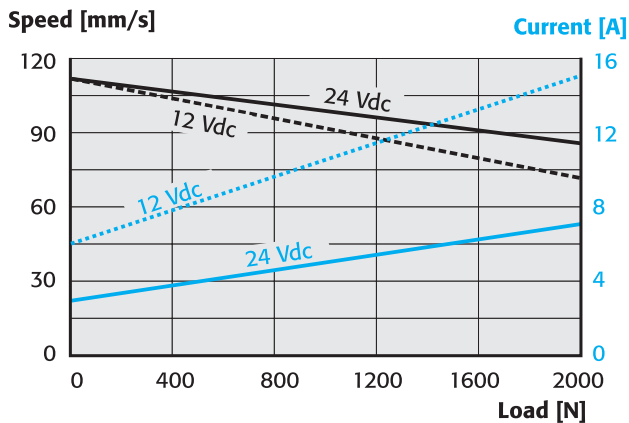

DT •• – B65M ••••• H •

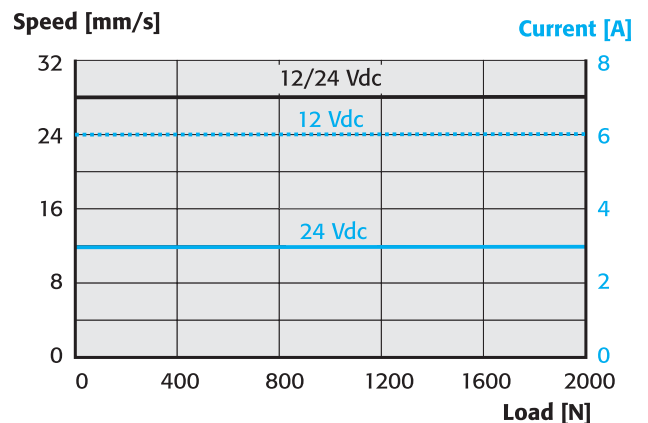

LoadMaster 80

Designation example	D	T	12	-	B61	M	080	A	C	V	X
Motor type Dc motor	D										
Actuator type LoadMaster 80		T									
Supply voltage 12 Vdc 24 Vdc			12 24								
Hyphen				-							
Screw type / diameter / lead Trapezoidal / 16 mm / 8 mm Ball screw / 16 mm / 10 mm Ball screw / 16 mm / 20 mm Ball screw / 15,88 mm / 5,08 mm					T68 B61 B62 B65						
Engineering unit Millimeter						M					
Stroke 50 cm 60 cm 70 cm 80 cm 90 cm 100 cm 110 cm 120 cm 130 cm 140 cm 150 cm							050 060 070 080 090 100 110 120 130 140 150				
Motor position 0° 60° 120° 180° 240° 300°								A B C D E F			
Motor enclosure With enclosure Without enclosure									C U		
Mounting position Vertical with motor down Vertical with motor down + spline safety function Horizontal										V F H	
Options No option Handwind											X H