



PROTECT YOUR INVESTMENT WITH BELLOWS

STANDARD AND CUSTOM MANUFACTURED BELLOWS AND COVERS, SEWN, MOLDED, WELDED, INTO ROUND, SQUARE OR RECTANGULAR SHAPES WITH COLLARS OR FLANGED ENDS.

Melbourne Tel: 03 9755 6044 Fax: 03 9755 6088  
 Sydney Tel: 02 9792 7188 Fax: 02 9792 2810  
 Brisbane Tel: 07 3274 3388 Fax: 07 3274 3400  
 Perth Tel: 08 9358 2444 Fax: 08 9358 2666  
 Adelaide Tel: 08 8283 4177 Fax: 08 8283 4188  
 Auckland Tel: 09 273 9723 Fax: 09 273 9725

## RECTANGULAR BELLOW SPECIFICATION SHEET

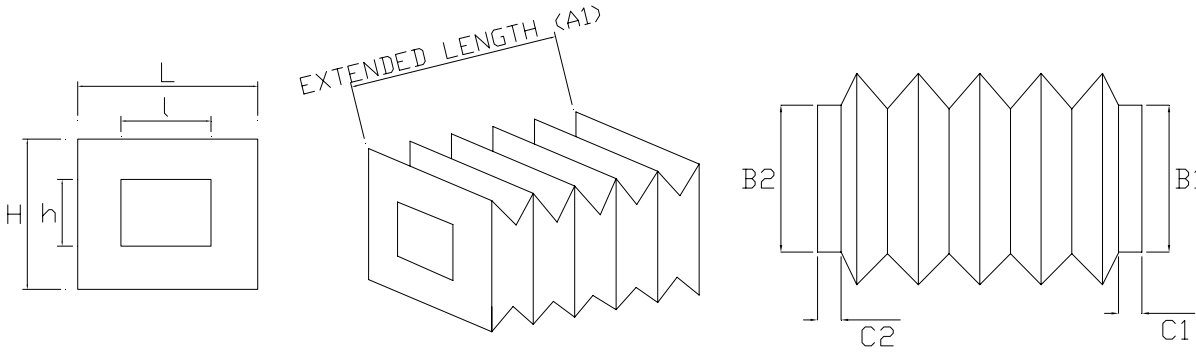
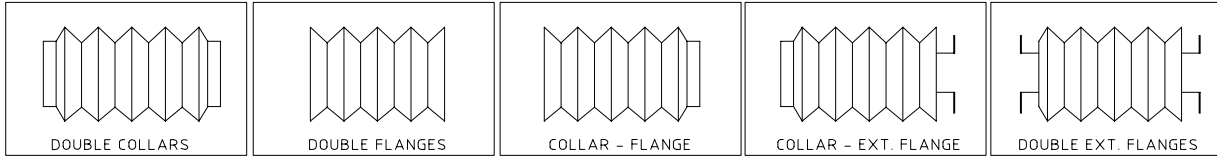

### ORDERING SPECIFICATIONS

EXTERNAL DIMENSIONS **L X H** \_\_\_\_\_ X \_\_\_\_\_

INTERNAL DIMENSIONS **l X h** \_\_\_\_\_ X \_\_\_\_\_

EXTENDED LENGTH EXCLUDING CUFFS **A.1.** \_\_\_\_\_

CLOSED LENGTH EXCLUDING CUFFS **A.2.** \_\_\_\_\_

CUFF SIZE REQUIRED **B.1.** \_\_\_\_\_

CUFF LENGTH REQUIRED FOR FASTENNING **C.1** \_\_\_\_\_

CUFF SIZE REQUIRED **B.2.** \_\_\_\_\_

CUFF LENGTH REQUIRED FOR FASTENNING **C.2.** \_\_\_\_\_

MATERIAL TYPE: \_\_\_\_\_

SPECIAL REQUIREMENTS: \_\_\_\_\_

- |   |  |
|---|--|
| <input type="checkbox"/> Indoor Use       | <input type="checkbox"/> Outdoor Use     |
| <input type="checkbox"/> Humidity         | <input type="checkbox"/> Dryness         |
| <input type="checkbox"/> Heat             | <input type="checkbox"/> Dust/Sand       |
| <input type="checkbox"/> Welding Splashes | <input type="checkbox"/> Saltwater       |
| <input type="checkbox"/> Rust Action      | <input type="checkbox"/> Abrasive Action |
| <input type="checkbox"/> Magnetic         | <input type="checkbox"/> Vacuum          |
| <input type="checkbox"/> Chips Large      | <input type="checkbox"/> Chips Small     |
| <input type="checkbox"/> Coolant Type     | <input type="checkbox"/> Oil Type        |

### Working Temperature (in ° C)

\_\_\_\_\_ Min    \_\_\_\_\_ Max    \_\_\_\_\_ Average

### Special Features Available On Request

.Int Support Rings for Horizontal Application	Double Stitch on Cuff Connections
.External Tie Straps for Vertical Application	Flange Connections, one end / both ends
.Binder on Convolution Joins; Inside & Outside	

**QTY:** \_\_\_\_\_ **COST PER UNIT \$** \_\_\_\_\_

### CUSTOMER DETAILS:

COMPANY NAME: \_\_\_\_\_

CONTACT NAME: \_\_\_\_\_

ADDRESS: \_\_\_\_\_

PHONE: \_\_\_\_\_ FAX: \_\_\_\_\_