

# Rack-toothed Rail Type LM Guide Model GSR-R

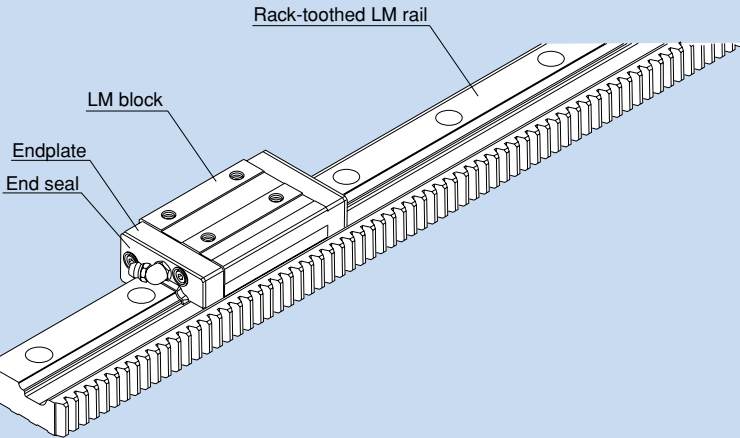

Fig1. Structure of Model GSR-R

## ● Structure and Features

Balls roll in two rows of raceways precision-ground on an LM rail and an LM block, and end-plates incorporated in the LM block allow the balls to circulate. Since retainer plates hold the balls, they do not fall off.

As the top face of the LM block is inclined, a clearance is eliminated and an appropriate preload is applied simply by securing the LM block with mounting bolts.

Model GSR-R is based on model GSR, but has rack teeth on the LM rail. This facilitates the design and assembly of drive mechanisms.

## ● Reduced machining and assembly costs

The single-piece structure integrating the LM rail (linear guide) and rack (drive) reduces labor and time for machining the rack mounting surface and assembling and adjusting the guide system, thus to achieve significant cost reduction.

## ● Easy designing

The travel distance per turn of the pinion is specified by the integer value. This makes it easy to calculate the travel distance per pulse when the LM Guide is used in combination with a stepping motor or servomotor.

## ● Space saving

Since the LM rail has rack teeth, the machine size can be reduced.

## ● Long stroke

The end faces of the LM rail are machined for connected use. To obtain a long stroke, simply connect LM rails of the standard length.

## ● High durability

The rack tooth has a width equal to the LM rail height, the rack uses high-grade steel with proven performance and the teeth are heat-treated, thereby to ensure high durability.

## ● Type and Features

### Model GSR-R (with a rack-teethed LM rail)

Since the thrust load on the pinion shaft can be kept low due to rack-pinion meshing, it is easy to design systems with pinion shaft bearings and tables that are not so rigid.

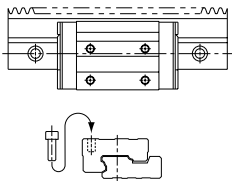

## ● Rated Loads in All Directions

Model GSR-R is capable of receiving loads in all four directions: radial, reverse-radial and lateral directions.

The basic load ratings indicate the values in the radial direction in Fig. 2, and their actual values are provided in the dimensional table for GSR-R. The values in the radial direction, tensile lateral direction and compressive lateral direction are obtained from table 1.

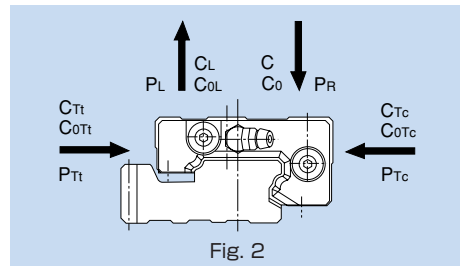

Fig. 2

Table 1 Basic Load Ratings of Model GSR-R in All Directions

| Direction                     | Basic dynamic load rating | Basic static load rating             |
|-------------------------------|---------------------------|--------------------------------------|
| Radial direction              | C                         | C <sub>0</sub>                       |
| Reverse-radial direction      | C <sub>L</sub> =0.93C     | C <sub>0L</sub> =0.90C <sub>0</sub>  |
| Tensile lateral direction     | C <sub>Tt</sub> =0.84C    | C <sub>0Tt</sub> =0.78C <sub>0</sub> |
| Compressive lateral direction | C <sub>Tc</sub> =0.93C    | C <sub>0Tc</sub> =0.90C <sub>0</sub> |

## Equivalent Load

When the LM block of model GSR-R receives loads in the radial, tensile lateral, reverse-radial and compressive lateral directions simultaneously, the equivalent load is obtained from the equation below.

$$P_E = X \cdot P_R + Y \cdot P_{Tt}$$

$$P_E = P_L + P_{Tc}$$

where

- $P_E$  : Equivalent load (N)
- Radial direction
  - Reverse-radial direction
  - Tensile lateral direction
  - Compressive lateral direction
- $P_R$  : Radial load (N)
- $P_L$  : Reverse-radial load (N)
- $P_{Tt}$  : Tensile lateral load (N)
- $P_{Tc}$  : Compressive lateral load (N)
- X/Y axes : Equivalent factor (see table 2)

Table 2 Equivalent Factor of Model GSR-R  
(When radial and tensile lateral loads are applied)

| $P_E$  | X     | Y    |
|--|-------|------|
| Equivalent load in radial direction          | 1     | 1.28 |
| Equivalent load in tensile lateral direction | 0.781 | 1    |

## Options

### Dust Prevention Accessories

THK offers various dust prevention accessories for model GSR-R.

When a dust prevention accessory is required, specify the desired item with the corresponding symbol provided in table 3 (for details of dust prevention accessories, see page a-24).

For supported model numbers for dust prevention accessories and overall LM block length with dust prevention accessories attached (dimension L), see page a-391.

Table 3 Symbols of Dust Prevention Accessories for Model GSR-R

| Symbol | Dust prevention accessory                     |
|--------|---|
| UU     | With end seal                                 |
| SS     | With end seal + side seal                     |
| DD     | With double seals + side seal                 |
| ZZ     | With end seal + side seal + metal scraper     |
| KK     | With double seals + side seal + metal scraper |

### Seal resistance value

For the maximum seal resistance value per LM block when a lubricant is applied on seals GSR-R...UU, refer to the corresponding value provided in table 4.

Table 4 Maximum Seal Resistance Value of Seals GSR-R...UU

Unit: N

| Model No. | Seal resistance value |
|-----------|-----------------------|
| GSR 25-R  | 4.4                   |
| GSR 30-R  | 6.3                   |
| GSR 35-R  | 7.6                   |

### ●Dedicated Cap C for LM Rail Mounting Holes

If any of the LM rail mounting holes of an LM Guide is filled with cutting chips or foreign matter, they may enter the LM block structure. Entrance of such foreign matter can be prevented by covering each LM rail mounting hole with the dedicated cap so that the top of the mounting holes is on the same level as the LM rail top face.

Since the dedicated cap C for LM rail mounting holes uses a special synthetic resin with high oil resistance and high wear resistance, it is highly durable.

When placing an order, specify the desired cap type with the corresponding cap number indicated in table 5.

For the procedure for mounting the cap, see page a-22.

Table 5 Major Dimensions of Dedicated Cap C

| Model No. | Cap C model No. | Bolt used | Major dimensions mm |     |
|-----------|-----------------|-----------|---------------------|-----|
|           |                 |           | D                   | H   |
| GSR 25-R  | C 6             | M 6       | 11.4                | 2.7 |
| GSR 30-R  | C 8             | M 8       | 14.4                | 3.7 |
| GSR 35-R  | C10             | M10       | 18.0                | 3.7 |

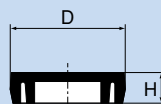

Dedicated Cap C

## ● Rack and Pinion

### ● Joining two or more rails

The end faces of the rack-toothed LM rail are machined so that a clearance is left after assembly in order to facilitate the assembly.

Use of a special jig as shown in Fig. 3 will make the connection easier.

(THK also offers the rack-aligning jig.)

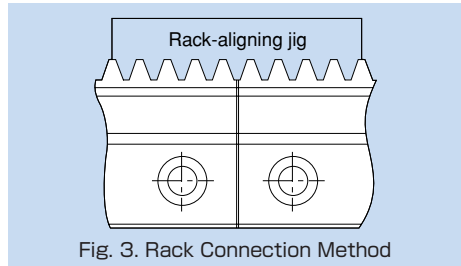

Fig. 3. Rack Connection Method

### ● Reworking the pinion hole

Only the teeth of the reworkable pinion-hole-diameter type (type C) are heat-treated. The hole and keyway can therefore be reworked by the user to the desired diameter and shape.

When reworking the pinion hole, be sure to take the following into account.

The material of the reworkable hole-diameter type (type C): S45C

- ① When chucking the teeth of a reworkable hole-diameter type, use a jaw scroll chuck or the like to maintain the tooth profile.
- ② The pinion is produced using the center of the hole as a reference point. The center of the hole should therefore be used as a reference point when the pinion is aligned. When checking the pinion run-out, refer to the boss sides.
- ③ Keep the reworked hole-diameter within roughly 60 to 70% of the boss diameter.

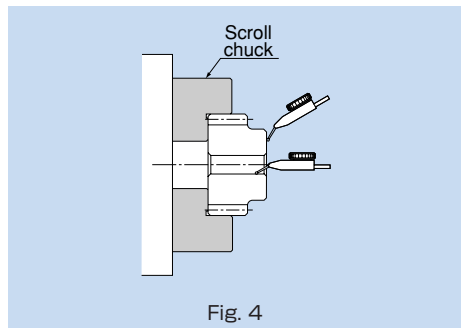

Fig. 4

### ● Lubricating the rack and pinion

To ensure smooth sliding on tooth surfaces and prevent wear, the teeth should be provided with a lubricant.

\*Use a lubricant of the same type as that contained in the LM Guide.

## ● Checking strength

The strength of the assembled rack and pinion must be checked in advance.

- ① Calculated the maximum thrust acting on the pinion.
- ② Divide the permissible power-transmission capacity of the pinion to be used (table 6) by an overload factor (table 7).
- ③ By comparing the thrust acting on the pinion obtained in step 1 with the pinion power-transmission capacity obtained in step 2, make sure the applied thrust does not exceed the permissible power-transmission capacity.

[Example of calculation]

Model GSR-R is used in a horizontal conveyance system receiving a medium impact (assuming external load to be zero).

### Conditions

|                                |                       |
|--------------------------------|-----------------------|
| Subject model No. (pinion)     | GP6-20A               |
| Mass (table + workpiece)       | m=100kg               |
| Speed                          | v=1 m/s               |
| Acceleration/deceleration time | T <sub>1</sub> =0.1 s |

### Consideration

- ① Calculating the maximum thrust  
Calculated the thrust during acceleration/deceleration.

$$F_{\max} = m \cdot \frac{v}{T_1} = 1.00\text{kN}$$

- ② Permissible power-transmission capacity of the pinion

$$P_{\max} = \frac{\text{permissible power-transmission capacity (see table 6)}}{\text{overload factor (see table 7)}}$$

$$= \frac{2.33}{1.25}$$

$$= 1.86\text{kN}$$

- ③ Comparison between the maximum thrust and the permissible power-transmission capacity of the pinion  
F<sub>max</sub><P<sub>max</sub>

Therefore, it is judged that the subject model number can be used.

Table 6 Permissible Power-transmission Capacity

Unit: kN

| Model No. | Permissible power-transmission capacity | Supported model |
|-----------|---|-----------------|
| GP 6-20A  | 2.33                                    | GSR 25-R        |
| GP 6-20C  | 2.05                                    |                 |
| GP 6-25A  | 2.73                                    |                 |
| GP 6-25C  | 2.23                                    | GSR 30-R        |
| GP 8-20A  | 3.58                                    |                 |
| GP 8-20C  | 3.15                                    |                 |
| GP 8-25A  | 4.19                                    | GSR 35-R        |
| GP 8-25C  | 3.42                                    |                 |
| GP10-20A  | 5.19                                    |                 |
| GP10-20C  | 4.57                                    |                 |
| GP10-25A  | 6.06                                    | GSR 35-R        |
| GP10-25C  | 4.96                                    |                 |

Table 7 Overload Factor

| Impact from the prime mover                                | Impact from the driven machine |               |              |
|--|--------------------------------|---------------|--------------|
|  | Uniform load                   | Medium impact | Large impact |
| Uniform load (prime mover, turbine, hydraulic motor, etc.) | 1.0                            | 1.25          | 1.75         |

(Excerpt from JGMA401-01)

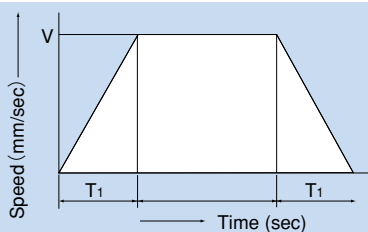
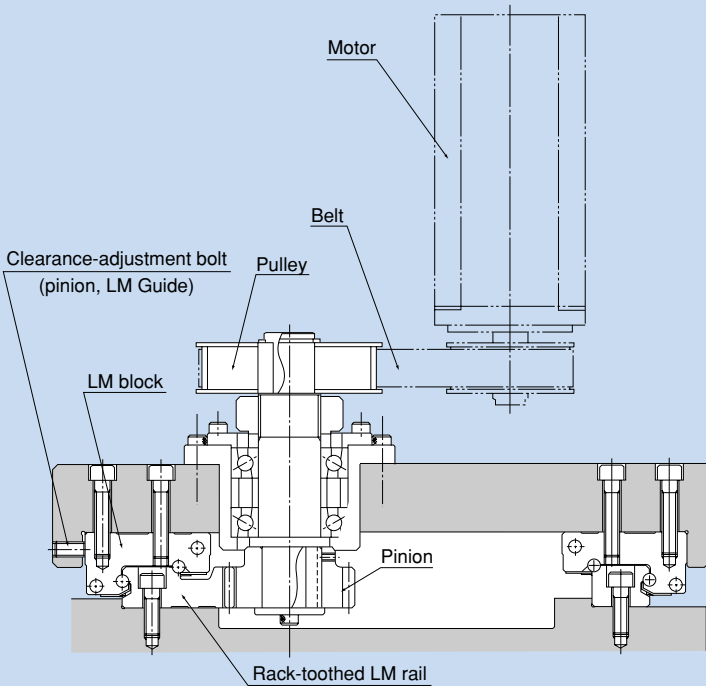
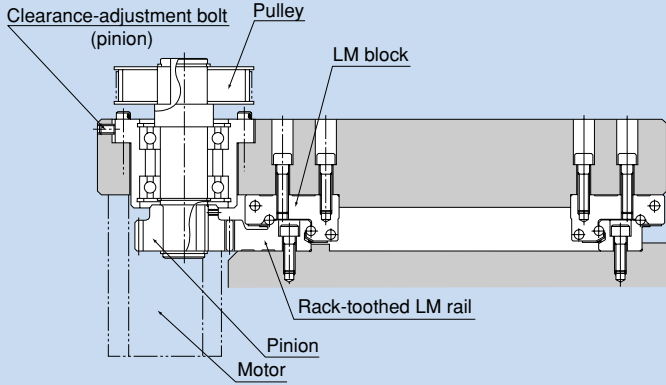

Fig. 5

## ● Example of Assembling Model GSR-R with the Table



## Standard Length of the LM Rail

Table 8 shows the standard LM rail lengths of model GSR-R variations.

Since both end faces of the LM rail of model GSR-R are machined, it can be joined with another rail without additional machining.

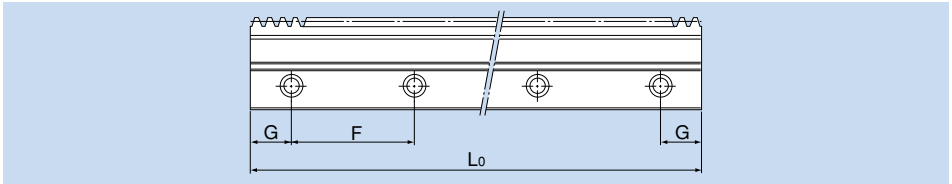
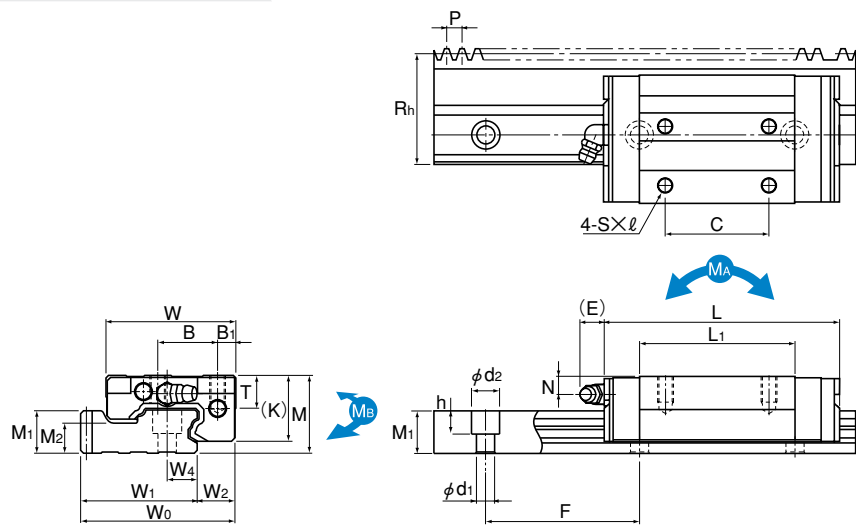

Table 8 Standard Length of the LM Rail for Model GSR-R

Unit: mm

| Model No.                         | GSR 25-R |      | GSR 30-R |      | GSR 35-R |      |
|-----------------------------------|----------|------|----------|------|----------|------|
| Standard LM rail length ( $L_0$ ) | 1500     | 2004 | 1504     | 2000 | 1500     | 2000 |
| Standard pitch F                  | 60       | 60   | 80       | 80   | 80       | 80   |
| G                                 | 30       | 42   | 32       | 40   | 30       | 40   |



Model GSR-T-R

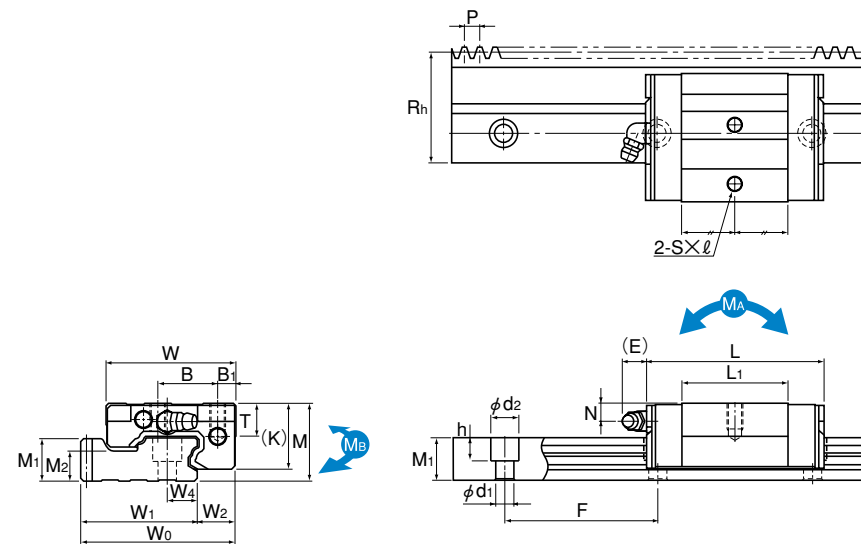

Model GSR25V-R

Unit: mm

| Model No. | Rack                        |        | External dimensions  |          |         | LM block dimensions   |     |                |    |    |       |                |      |      |   | LM rail dimensions |               |                      |                |                | Basic load rating     |         | Static permissible moment kN-m* |                                     |         |                           | Mass           |                           |          |         |      |     |
|-----------|-----------------------------|--------|----------------------|----------|---------|-----------------------|-----|----------------|----|----|-------|----------------|------|------|---|--------------------|---------------|----------------------|----------------|----------------|-----------------------|---------|---------------------------------|-------------------------------------|---------|---------------------------|----------------|---------------------------|----------|---------|------|-----|
|           | Reference pitch dimension P | Module | Pitch line height Rh | Height M | Width W | Length W <sub>0</sub> | L   | B <sub>1</sub> | B  | C  | S × l | L <sub>1</sub> | T    | K    | N | E                  | Grease nipple | Width W <sub>1</sub> | W <sub>2</sub> | W <sub>4</sub> | Height M <sub>1</sub> | Pitch F | M <sub>2</sub>                  | d <sub>1</sub> × d <sub>2</sub> × h | C       | C <sub>0</sub>            | M <sub>A</sub> | M <sub>B</sub>            | LM block | LM rail |      |     |
|           |                             |        |                      |          |         |                       |     |                |    |    |       |                |      |      |   |                    |               |                      |                |                |                       |         |                                 |                                     | 1 block | 2 blocks in close contact | 1 block        | 2 blocks in close contact | kg       | kg/m    |      |     |
| GSR 25T-R | 6                           | 1.91   | 43                   | 30       | 50      | 59.91                 | 88  | 7              | 23 | 40 | M6×10 | 60.2           | 12.7 | 25.5 | 7 | 12                 | B-M6F         | 44.91                | 15             | 11.5           | 16.5                  | 60      | 11.5                            | 7×11×9                              | 13.5    | 19                        | 0.177          | 0.965                     | 0.152    | 0.831   | 0.5  | 4.7 |
| GSR 25V-R | 6                           | 1.91   | 43                   | 30       | 50      | 59.91                 | 69  | 7              | 23 | —  | M6×10 | 41.2           | 12.7 | 25.5 | 7 | 12                 | B-M6F         | 10.29                | 12.65          | 11.5           | 16.5                  | 60      | 11.5                            | 7×11×9                              | 10.29   | 12.65                     | 0.0858         | 0.522                     | 0.0742   | 0.451   | 0.29 | 4.7 |
| GSR 30T-R | 8                           | 2.55   | 48                   | 33       | 57      | 67.05                 | 103 | 8              | 26 | 45 | M8×12 | 70.3           | 14.6 | 28.5 | 7 | 12                 | B-M6F         | 50.55                | 16.5           | 14             | 19                    | 80      | 12                              | 9×14×12                             | 18.8    | 25.9                      | 0.282          | 1.54                      | 0.243    | 1.32    | 0.6  | 5.9 |
| GSR 35T-R | 10                          | 3.18   | 57                   | 38       | 68      | 80.18                 | 117 | 9              | 32 | 50 | M8×15 | 80.3           | 15.6 | 32.5 | 8 | 12                 | B-M6F         | 60.18                | 20             | 17             | 22                    | 80      | 14.5                            | 11×17.5×14                          | 25.1    | 33.8                      | 0.421          | 2.28                      | 0.362    | 1.96    | 1    | 8.1 |

**Note** A special type with a module pitch is also available. Contact THK for details. For checking the pinion strength, see pages a-385.

**Note** A moment in the direction MC can be received if two rails are used in parallel. However, since it depends on the distance between the two rails, the moment in the direction MC is omitted here.

Static permissible moment\* 1 block: static permissible moment value with 1 LM block  
2 blocks: static permissible moment value with 2 blocks closely contacting with each other

### Model number coding

Single-rail LM Guide

**GSR25T 2 UU +5000L H R T**

1 2 3 4 5 6 7

- 1 Model number
- 2 No. of LM blocks
- 3 Dust prevention accessory symbol (see page a-382)
- 4 LM rail length (in mm)
- 5 Accuracy symbol (see page a-44)
- 6 Symbol for rack-toothed LM rail type
- 7 Symbol for connected use\*\*

\*\*For combinations of lengths when rails are connected, contact THK.

**Note** This model number indicates that a single-rail unit constitutes one set.

### Model number coding

LM block

**GSR25T UU**

1 2

- 1 Model number
- 2 Dust prevention accessory symbol (see page a-382)

### Model number coding

Rack-toothed LM rail

**GSR25-2004L H R**

1 2

- 1 Accuracy symbol (see page a-44)
- 2 R: Symbol for rack-toothed LM rail type

# Pinion

## Pinion Type A for the Rack

Keyway type

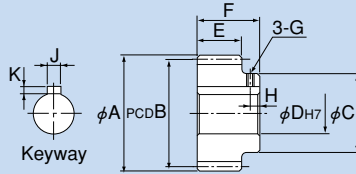

Unit: mm

| Model No. | Pitch | No. of teeth | Tip circle diameter<br>A | Meshing PCD<br>B | Boss diameter<br>C | Hole diameter<br>D | Tooth width<br>E | Total length<br>F | G  | H | Keyway<br>J×K | Supported model |
|-----------|-------|--------------|--------------------------|------------------|--------------------|--------------------|------------------|-------------------|----|---|---------------|-----------------|
| GP 6-20A  | 6     | 20           | 42.9                     | 39               | 30                 | 18                 | 16.5             | 24.5              | M3 | 4 | 6×2.8         | GSR 25-R        |
| GP 6-25A  |       | 25           | 51.9                     | 48               | 35                 | 18                 |                  |                   |    |   |               |                 |
| GP 8-20A  | 8     | 20           | 57.1                     | 52               | 40                 | 20                 | 19               | 26                | M3 | 5 | 8×3.3         | GSR 30-R        |
| GP 8-25A  |       | 25           | 69.1                     | 64               | 40                 | 20                 |                  |                   |    |   |               |                 |
| GP10-20A  | 10    | 20           | 70.4                     | 64               | 45                 | 25                 | 22               | 30                | M4 | 5 | 8×3.3         | GSR 35-R        |
| GP10-25A  |       | 25           | 86.4                     | 80               | 60                 | 25                 |                  |                   |    |   | 10×3.3        |                 |

Note 1: When making an order, specify the corresponding model number from the table.

Note 2: Non-standard (e.g., number of teeth) types of pinion are also available. Contact THK for details.

## Pinion Type C for the Rack

Reworkable hole-diameter type

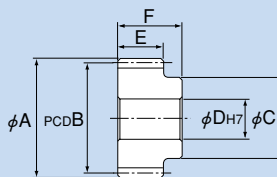

Unit: mm

| Model No. | Pitch | No. of teeth | Tip circle diameter<br>A | Meshing PCD<br>B | Boss diameter<br>C | Hole diameter<br>D | Tooth width<br>E | Total length<br>F | Supported model |
|-----------|-------|--------------|--------------------------|------------------|--------------------|--------------------|------------------|-------------------|-----------------|
| GP 6-20C  | 6     | 20           | 42.9                     | 39               | 30                 | 12                 | 16.5             | 24.5              | GSR 25-R        |
| GP 6-25C  |       | 25           | 51.9                     | 48               | 35                 | 15                 |                  | 24.5              |                 |
| GP 8-20C  | 8     | 20           | 57.1                     | 52               | 40                 | 18                 | 19               | 26                | GSR 30-R        |
| GP 8-25C  |       | 25           | 69.1                     | 64               | 40                 | 18                 |                  | 26                |                 |
| GP10-20C  | 10    | 20           | 70.4                     | 64               | 45                 | 18                 | 22               | 30                | GSR 35-R        |
| GP10-25C  |       | 25           | 86.4                     | 80               | 60                 | 18                 |                  | 30                |                 |

Note 1: When making an order, specify the corresponding model number from the table.

Note 2: Non-standard (e.g., number of teeth) types of pinion are also available. Contact THK for details.

## ■ Dimensions When the LM Rail Is Used in Combination with a Pinion

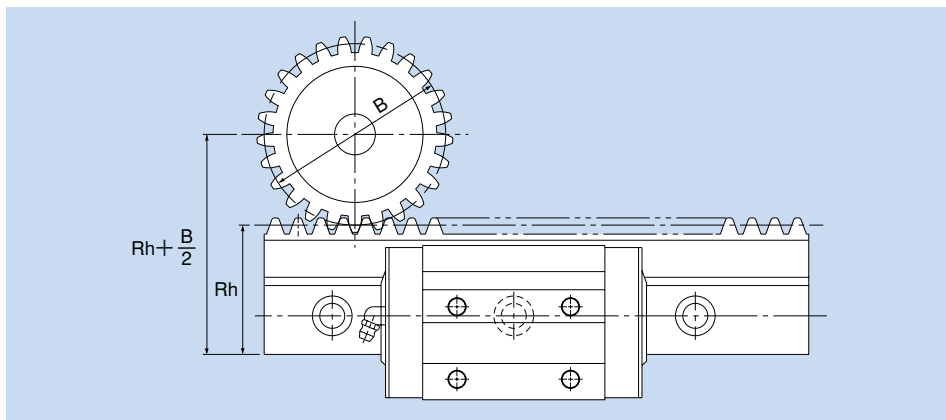

Unit: mm

| GSR model No. | Pinion model No. | LM rail pitch line height Rh | Pinion meshing PCD B | Rh+B/2 |
|---------------|------------------|------------------------------|----------------------|--------|
| GSR 25-R      | GP 6-20A         | 43                           | 39                   | 62.5   |
|               | GP 6-20C         |                              | 48                   | 67     |
|               | GP 6-25A         |                              |                      |        |
|               | GP 6-25C         |                              |                      |        |
| GSR 30-R      | GP 8-20A         | 48                           | 52                   | 74     |
|               | GP 8-20C         |                              | 64                   | 80     |
|               | GP 8-25A         |                              |                      |        |
|               | GP 8-25C         |                              |                      |        |
| GSR 35-R      | GP 10-20A        | 57                           | 64                   | 89     |
|               | GP 10-20C        |                              | 80                   | 97     |
|               | GP 10-25A        |                              |                      |        |
|               | GP 10-25C        |                              |                      |        |

## ● Overall LM Block Length with Options

### ■ Overall LM Block Length (Dimension L) of Model GSR-R with a Dust Prevention Accessory Attached

Unit: mm

| Model No. | JJ  | SS  | DD    | ZZ    | KK    |
|-----------|-----|-----|-------|-------|-------|
| GSR 25T-R | 88  | 88  | 95    | 91.6  | 98.6  |
| GSR 25V-R | 69  | 69  | 76    | 72.6  | 79.6  |
| GSR 30T-R | 103 | 103 | 110.6 | 107.2 | 114.8 |
| GSR 35T-R | 117 | 117 | 124.6 | 121.2 | 128.8 |