

Rotary Ball Spline Models LBG and LBGT

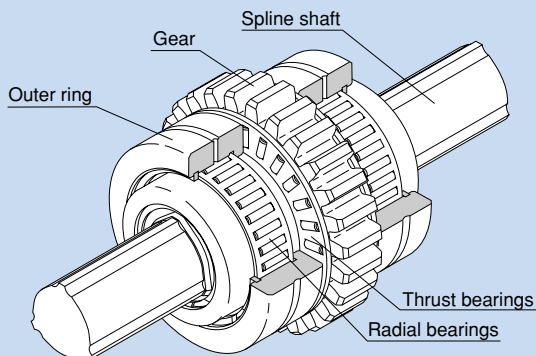

Fig. 1 Structure of Rotary Ball Spline Model LBG

● Structure and Features

With rotary Ball Spline models LBG and LBGT, the spline shaft has three crests on the circumference, and along both sides of each crest, two rows of balls (six rows in total) are arranged to hold the crest so that a reasonable preload is applied.

These models are unit types based on model LBR, but have gear teeth on the flange circumference and radial and thrust bearings on the spline nut, all compactly integrated.

The rows of balls are held in a special resin retainer so that they smoothly roll and circulate. With this design, balls will not fall even if the spline shaft is removed.

● No Angular Backlash

The spline shaft has three crests positioned equidistantly at 120° , and along both sides of each crest, two rows of balls (six rows in total) are arranged so as to hold the crest at a contact angle of 45° and provide a preload. As a result, backlash in the rotational direction is eliminated and the rigidity is increased.

● Compact design

The spline nut is compactly integrated with radial and thrust bearings, allowing compact design to be achieved.

● High Rigidity

Since the contact angle is large and an appropriate preload is given, high rigidity against torque and moment is achieved. Use of needle bearings in the support unit achieves a rigid nut support strong against a radial load.

● Optimal for Torque Transmission with Spline Nut Drive

Since the support bearings allow a rigid nut support, these models are optimal for torque transmission with spline nut drive.

● Types and Features

● Types of Spline Nuts

Ball Spline with Gears Model LBG



Without a thrust raceway

A unit type based on model LBR, but has gear teeth on the flange circumference and radial and thrust needle bearings on the spline nut, all compactly integrated. It is optimal for a torque transmission mechanism with spline nut drive.

Ball Spline with Gears Model LBGT



With a thrust raceway

A unit type based on model LBR, but has gear teeth on the flange circumference and radial and thrust needle bearings on the spline nut, all compactly integrated. It is optimal for a torque transmission mechanism with spline nut drive.

● Types of Spline Shafts

For details on spline shaft types, see page b-21.

● Housing Inner-diameter Tolerance

Table 1 shows housing inner-diameter tolerance for models LBG and LBGT.

Table 1 Housing Inner-diameter Tolerance

Housing inner-diameter tolerance	General service conditions	H7
	When clearance needs to be small	J6

Spline Shaft

Spline shafts are divided in shape into precision solid spline shaft, special spline shaft and hollow spline shaft (type K), as described on page b-21.

Since production of a spline shaft with a specific shape is performed at your request, provide a drawing of the desired shaft shape when asking an estimate or placing an order.

Sectional Shape of the Spline Shaft

Table 2 shows the sectional shape of a spline shaft. If the spline shaft ends need to be cylindrical, the minor diameter (d) value should not be exceeded if possible.

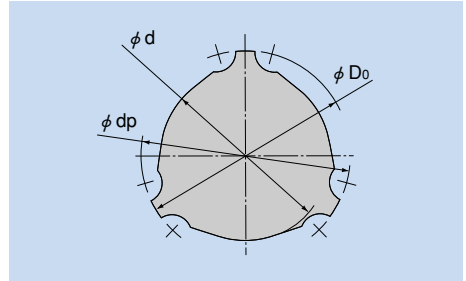

Table 2 Sectional Shape of the Spline Shaft

Unit: mm

Nominal shaft diameter	20	25	30	40	50	60	85
Minor diameter d	15.3	19.5	22.5	31	39	46.5	67
Major diameter D_0	19.7	24.5	29.6	39.8	49.5	60	84
Ball center diameter d_p	20	25	30	40	50	60	85
Mass (kg/m)	1.8	2.7	3.8	6.8	10.6	15.6	32

Hole Shape of the Standard Hollow Type Spline Shaft

Table 3 shows the hole shape of the standard hollow type spline shaft (type K) for models LBG and LBGT.

Use this table when a requirement such as piping, wiring, air-vent or weight reduction needs to be met.

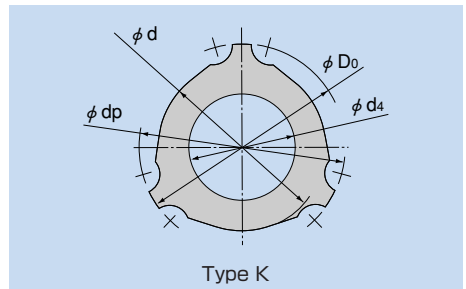

Table 3 Sectional Shape of the Standard Hollow Type Spline Shaft

Unit: mm

Nominal shaft diameter	20	25	30	40	50	60	85
Minor diameter d	15.3	19.5	22.5	31	39	46.5	67
Major diameter D_0	19.7	24.5	29.6	39.8	49.5	60	84
Ball center diameter d_p	20	25	30	40	50	60	85
Hole diameter d_4	6	8	12	18	24	30	45
Mass (kg/m)	1.6	2.3	2.9	4.9	7	10	19.5

● Chamfering of the Spline Shaft Ends

For details on chamfering of the spline shaft ends, see page b-24.

● Length of Incomplete Section of a Special Spline Shaft

If the middle area or the end of a spline shaft is to be thicker than the minor diameter (d), an incomplete spline section is required to secure a recess for grinding. Table 4 shows the relationship between the length of the incomplete section (S) and the flange diameter (df). (This table does not apply to overall length of 1,500 mm or greater. Contact **THK** for details.)

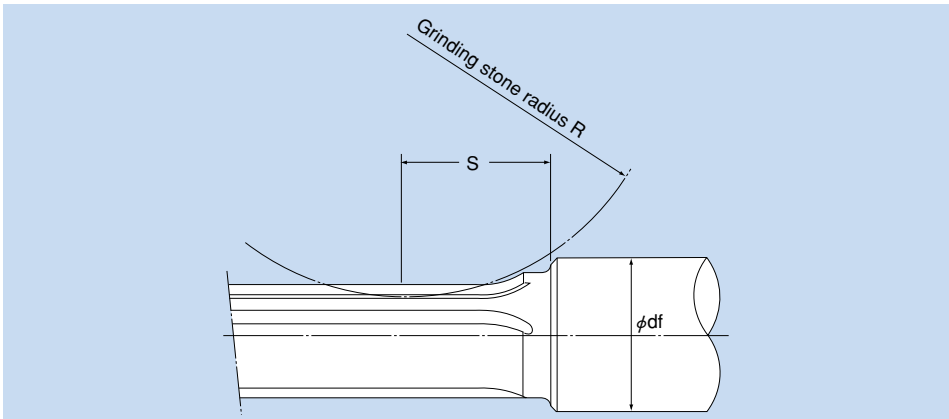
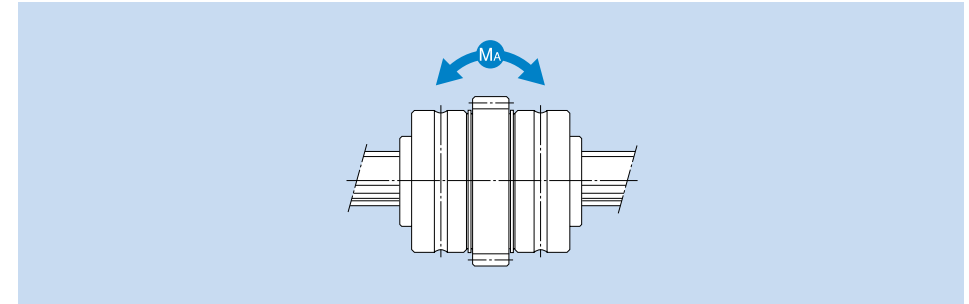
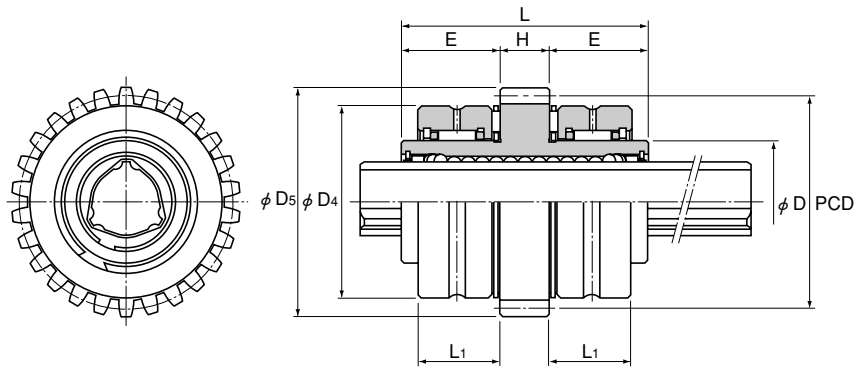

Table 4 Length of Incomplete Spline Section: S

Unit: mm

Flange diameter df / Nominal shaft diameter	20	25	30	35	40	50	60	80	100	120	140
20	25	36	43	48	53	—	—	—	—	—	—
25	—	32	46	55	62	73	—	—	—	—	—
30	—	—	35	48	56	69	78	—	—	—	—
40	—	—	—	—	38	59	71	88	—	—	—
50	—	—	—	—	—	42	61	82	96	—	—
60	—	—	—	—	—	—	45	74	91	102	—
70	—	—	—	—	—	—	—	64	85	98	108
85	—	—	—	—	—	—	—	34	72	90	102



Unit: mm

Model No.	Spline nut dimensions										Gear specifications*				Basic torque rating		Basic load rating		Permissible static moment MA** N·m	Mass		
	Spline nut outer diameter		Length		Outer diameter		Width		H	E	Tooth end diameter D _s	Standard pitch diameter PCD	Module m	No. of teeth z	C _T N·m	C _{OT} N·m	C kN	C _o kN		Spline nut unit kg	Spline shaft kg/m	
● LBG 20	30	0 -0.009	60	0	47	0 -0.011	20	0 -0.16	12	24	56	52	2	26	90.2	213	9.4	20.1	103	0.61	1.8	
● LBG 25	40	0	70		60	0	23	0	14	28	70	65	2.5	26	176	381	14.9	28.7	171	1.4	2.7	
● LBG 30	45	-0.011	80		65	-0.013	27	-0.19	16	32	75	70	2.5	28	312	657	22.5	41.4	295	2.1	3.8	
● LBG 40	60	0	100	0	85	0	31	0	18	41	96	90	3	30	696	1420	37.1	66.9	586	3	6.8	
● LBG 50	75	-0.013	112		100	-0.015	32		0	20	46	111	105	3	35	1290	2500	55.1	94.1	941	4.1	10.6
● LBG 60	90	0	127		120	-0.015	38		-0.25	22	52.5	133	126	3.5	36	1870	3830	66.2	121	1300	6.3	15.6
● LBG 85	120	-0.015	155	-0.3	150	0 -0.025	40		26	64.5	168	160	4	40	4740	9550	119	213	3180	11.8	32	

Note ● indicates model numbers for which felt seal types are available (see page b-8).

Note *The gear specifications in the table represent the dimensions with maximum module. Special gear types such as helical gear and worm gear can also be manufactured at your request.

**MA indicates the permissible moment value in the axial direction when a single spline nut is used, as shown in the figure above.

Model number coding

2 LBG50 DD CM +700L H K

1 2 3 4 5 6 7

1 Number of spline nuts on one shaft (no symbol for one nut)

2 Model No.

3 Dust prevention accessory symbol - no symbol: without seal

UU: rubber seal attached on both ends of spline nut

U: rubber seal attached on either end of spline nut

DD: felt seal attached on both ends of spline nut

D: felt seal attached on either end of spline nut

4 Symbol for clearance in the rotational direction (see page b-4)

5 Overall spline shaft length (in mm)

6 Accuracy symbol (see page b-5)

7 Symbol for standard hollow spline shaft (see page b-60) (no symbol: solid spline shaft)

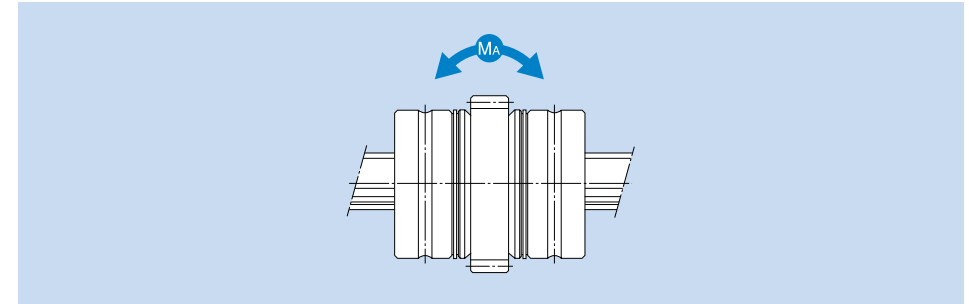
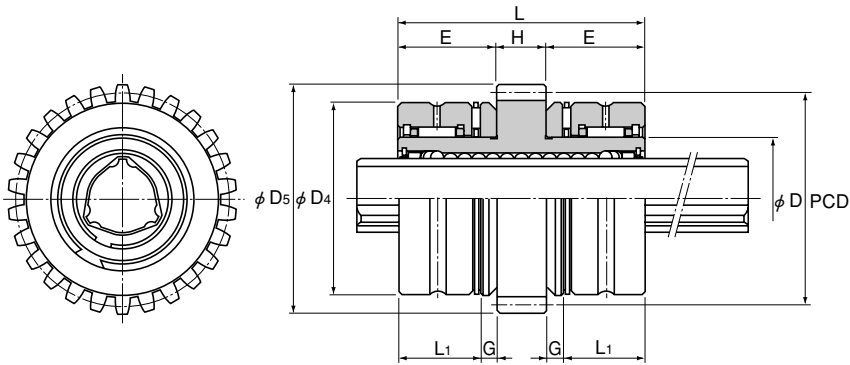

Unit: mm

Model No.	Spline nut outer diameter		Length		Spline nut dimensions				Gear specifications*				Basic torque rating		Basic load rating		Permissible static moment M _A ** N·m	Mass				
	D	Tolerance	L	Tolerance	Outer diameter D ₄	Tolerance	Width L ₁	Tolerance	Thrust race-way width G	H	E	Tooth end diameter D _s	Standard pitch diameter PCD	Module m	No. of teeth z	C _T N·m		C _{OT} N·m	C kN	C _o kN	Spline nut unit kg	Spline shaft kg/m
● LBGT 20	30	0 ^{-0.009}	60	0	47	0 ^{-0.011}	20	0 ^{-0.16}	4	12	24	56	52	2	26	90.2	213	9.4	20.1	103	0.67	1.8
● LBGT 25	40	0	70		60	0	23	0	5	14	28	70	65	2.5	26	176	381	14.9	28.7	171	1.5	2.7
● LBGT 30	45	-0.011	80	-0.2	65	-0.013	27	-0.19	5	16	32	75	70	2.5	28	312	657	22.5	41.4	295	2.2	3.8
● LBGT 40	60	0	100	0	85	0	31	0	8	18	41	96	90	3	30	696	1420	37.1	66.9	586	3.3	6.8
● LBGT 50	75	-0.013	112		100	-0.015	32		10	20	46	111	105	3	35	1290	2500	55.1	94.1	941	4.8	10.6
● LBGT 60	90	0	127	-0.3	120	0	38	-0.25	12	22	52.5	133	126	3.5	36	1870	3830	66.2	121	1300	7.2	15.6
● LBGT 85	120	-0.015	155	0	150	0 ^{-0.025}	40	0	16	26	64.5	168	160	4	40	4740	9550	119	213	3180	13.4	32

Note ● indicates model numbers for which felt seal types are available (see page b-8).

Note *The gear specifications in the table represent the dimensions with maximum module. Special gear types such as helical gear and worm gear can also be manufactured at your request.

**M_A indicates the permissible moment value in the axial direction when a single spline nut is used, as shown in the figure above.

Model number coding

2 LBGT40 UU CL +700L P K

1 Number of spline nuts on one shaft (no symbol for one nut)

2 Model No.

3 Dust prevention accessory symbol - no symbol: without seal

UU: rubber seal attached on both ends of spline nut

U: rubber seal attached on either end of spline nut

DD: felt seal attached on both ends of spline nut

D: felt seal attached on either end of spline nut

4 Symbol for clearance in the rotational direction (see page b-4)

5 Overall spline shaft length (in mm)

6 Accuracy symbol (see page b-5)

7 Symbol for standard hollow spline shaft (see page b-60) (no symbol: solid spline shaft)