

ACTUATOR LA36

Features:

- 12, 24 or 36 V DC Permanent magnetic motor with resettable thermal overload protection
- Max. thrust 1700 N, 2600 N, 4500 N or 6800 N depending on gear ratio and spindle
- Max. speed up to 68 mm/sec. depending on load and spindle
- Heavy duty aluminium housing for harsh conditions
- Highly efficient acme thread spindle
- Protection class: IP66 for outdoor use (dynamic), furthermore the actuator can be washed down by a high pressure cleaner (IP69K – static)
- Hand crank for manual operation
- Mechanical overload protection through integrated slip clutch (adjusted to 1.2 - 1.5 times max. load)
- Integrated brake, high self-lock ability
- End play – 2 mm max.
- Non rotating piston rod eye
- Back fixture turnable in steps of 30 degrees
- Turnable piston rod eye (0 – 90 degrees)

Options:

- Built in end stop switches
- Adjustable magnetic sensors for end stop signals (code no. 1017031)
- Hall effect sensor with A/B –signal
- Potentiometer full scale at 500 mm stroke with 12 mm pitch and 833 mm with 20 mm pitch
- Different back fixtures and piston rod eyes
- Exchangeable cables in different lengths

Usage:

- Duty cycle at max. load 20% (up to 600 mm stroke, for strokes between 601-999 mm the max. duty cycle is 15%) at ambient temperature 25°C
- Ambient operating temperature -30°C to +65°C, full performance from 5 - 40°C



TECHLINE™
IMPROVING FLEXIBILITY

LA36 is ideal for use in harsh conditions. It is our most solid actuator based on the philosophy that it must be able to operate under extreme conditions. The actuator is ideal for mobile "off-highway" equipment such as agricultural, forestry and construction machines.

Technical specifications

LA36 with 12V motor

Order number	Push max. (N)	Pull max. (N)	*Self-lock max. (N) Push	*Self-lock max. (N) Pull	Pitch (mm/spindle rev.)	Typical speed (mm/s)		Standard stroke lengths (mm) In steps of 50 mm	Typical amp. (A) 12 V	
						no Load	full Load		No load	Full load
363AXXXXXXXXXXX	2600	2600	3400	3400	12	40.7	30.6	100 - 999	4.5	21
363BXXXXXXXXXXXX	4500	4500	5800	5800	12	23.1	17.8	100 - 999*	4.5	20.7
363CXXXXXXXXXXXX	6800	6800	8800	8800	12	15.5	11.9	100 - 999*	4.5	21
365AXXXXXXXXXXXXX	1700	1700	2200	2200	20	68	52	100 - 999	4.5	22

LA36 with 24V motor

Order number	Push max. (N)	Pull max. (N)	*Self-lock max. (N) Push	*Self-lock max. (N) Pull	Pitch (mm/spindle rev.)	Typical speed (mm/s)		Standard stroke lengths (mm) In steps of 50 mm	Typical amp. (A) 24 V	
						no Load	full Load		No load	Full load
363AXXXXXXXXXXXXX	2600	2600	3400	3400	12	41	32.3	100 - 999	2.4	10.4
363BXXXXXXXXXXXX	4500	4500	5800	5800	12	23.3	18.9	100 - 999*	2.4	10.2
363CXXXXXXXXXXXX	6800	6800	8800	8800	12	15.7	12.7	100 - 999*	2.4	10.3
365AXXXXXXXXXXXXX	1700	1700	2200	2200	20	68	52	100 - 999	2.4	10.3

LA36 with 36V motor

Order number	Push max. (N)	Pull max. (N)	*Self-lock max. (N) Push	*Self-lock max. (N) Pull	Pitch (mm/spindle rev.)	Typical speed (mm/s)		Standard stroke lengths (mm) In steps of 50 mm	Typical amp. (A) 36 V	
						no Load	full Load		No load	Full load
363AXXXXXXXXXXXXX	2600	2600	3400	3400	12	41	33.5	100 - 999	2.0	8.0
363BXXXXXXXXXXXX	4500	4500	5800	5800	12	23.3	19.1	100 - 999*	2.0	8.0
363CXXXXXXXXXXXX	6800	6800	8800	8800	12	15.7	12.8	100 - 999*	2.0	8.0
365AXXXXXXXXXXXXX	1700	1700	2200	2200	20	68	52	100 - 999	2.0	8.0

* There are limitations on the stroke length if you need full load, please contact your nearest LINAK dealer for further details.

Graphs:

LA36 12V motor current v's load

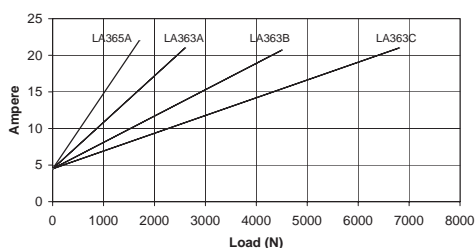

LA36 12V motor speed v's load

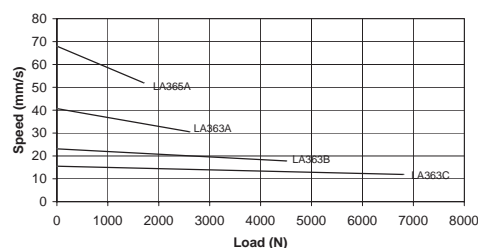

LA36 24V motor current v's load

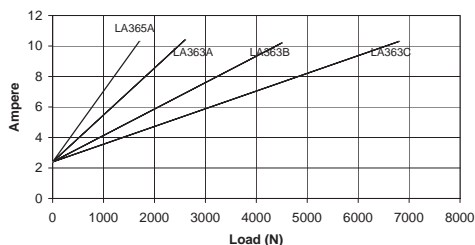

LA36 24V motor speed v's load

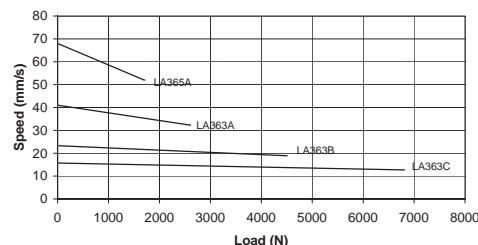

LA36 36V motor current v's load

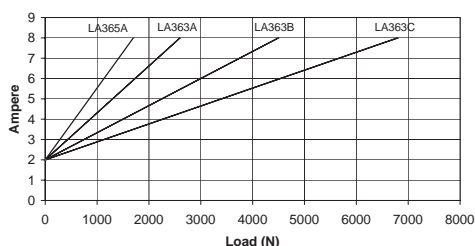

LA36 36V motor speed v's load

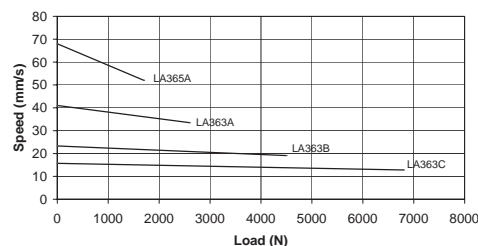

The above values are with an ambient temperature of 25°C and a stable power supply.

LA36

Ordering example:

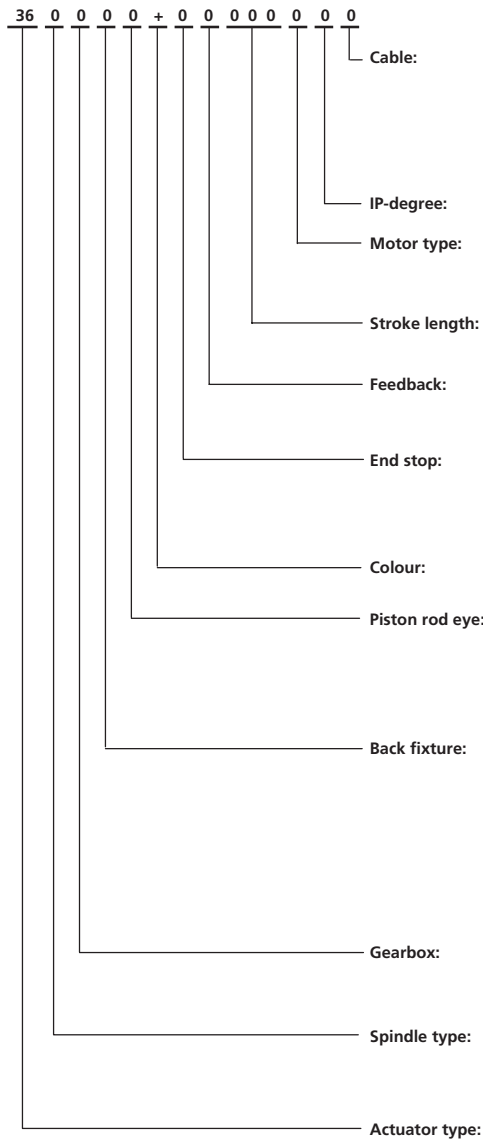

- 0 = No cable**
 - 1 = 1.5 m power cable (0367002-1500)
 - 2 = 5 m power cable (0367002-5000)
 - 3 = 0.2 m power cable with AMP connector (0367006)
 - 4 = 1.5 m power and 1.5 signal (0367002-1500+0367003-1500)
 - 5 = 5 m power and 5 m signal (0367002-5000+0367003-5000)
 - 6 = 1.5 m Y-cable, power and signal in one (0367020)
- 2 = Standard (IP66)**
- A = 12 V DC with clutch**
B = 24 V DC with clutch
C = 36 V DC with clutch
- XXX = mm Acme spindle:**
 100, 150...999 mm
- 0 = Standard (No feedback)**
H = Hall signal
P = Potentiometer
- 0 = No limit switches**
 - 1 = With limit switches
 - 2 = With limit switches and end-stop signals
 - 3 = CS36
 - 4 = CS36 with end-stop signals
- + = Without safety nut - Standard**
5 = With safety nut - only in push
- 0 = M20 X 1 female adapter - 0361016**
 - 1 = ø 12.9 mm hole, for 1/2" pin - 0361018-B
 - 2 = ø 12.2 mm hole, for 12 mm pin - 0361109-B
 - 3 = M12 X 1.75 male adapter - 0361224
 - 4 = M16 X 1.75 male adapter - 0361135
 - 5 = ø 12.2 hole with slot (like LA34) - 0361138
- 0 = M20 X 1 female adapter - 0361128**
 - 1 = ø 12.9 mm hole, for 1/2" pin - 0361129
 - 2 = ø 12.9 mm hole turned 90°, for 1/2" pin - 0361129
 - 3 = ø 12.2 mm hole, for 12 mm pin - 0361119
 - 4 = ø 12.2 mm hole turned 90°, for 12 mm pin - 0361119
 - 5 = M12 X 1.75 male adapter - 0361126
 - 6 = M16 X 1.75 male adapter - 0361247
 - 7 = ø 12.2 hole with slot (like LA34) - 0361140
 - 8 = ø 12.2 hole with slot (like LA34) turned 90° - 0361140
- | | 12 mm pitch | 20 mm pitch |
|------------------------------|-------------|-------------|
| A = Gear ratio 1 : 18 | 2.600 N | 1.700 N |
| B = Gear ratio 1 : 31 | 4.500 N | N.A. |
| C = Gear ratio 1 : 46 | 6.800 N | N.A. |
- 3 = 3-threaded acme spindle (12 mm pitch)**
5 = 5-threaded acme spindle (20 mm pitch)
C = 3 + adjustable reed limit switches (on outer tube)
E = 5 + adjustable reed limit switches (on outer tube)
- 36 = LA36**

Available Circuits (LINAK code 1017031):

		415A3
Connection Code		V
Cable code		108
Circuit style		B
Contact		N.O.
Connection		PNP
Indication		LED
Voltage V DC		5...30
Voltage V AC		5...30
Max voltage drop	V	0.1
Max power	W	10
Max current	mA	50
Varistor	V	-
Cable size	mm ²	3 x 0,14
Sheath		PVC

Circuit styles:

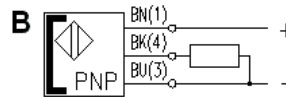

LA36 dimensions:

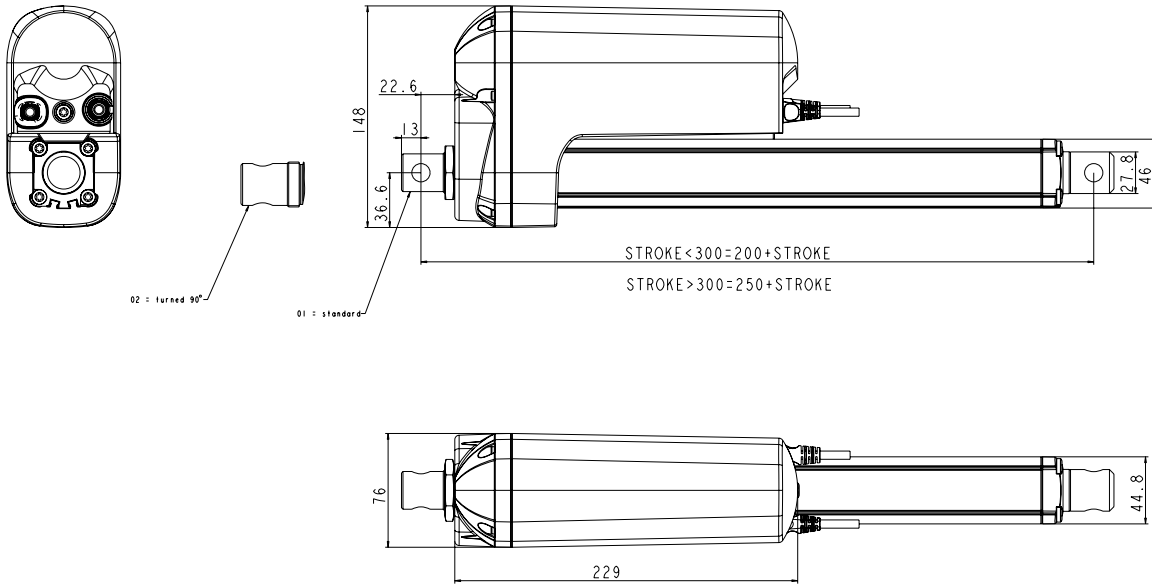

LA36 with adapter:

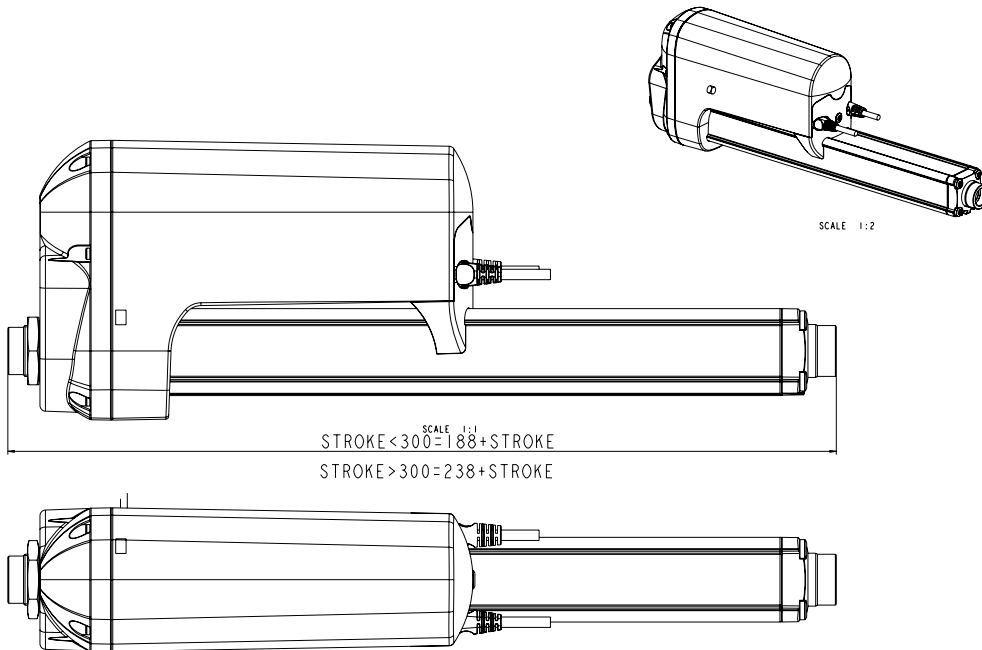

Adapter part number: 0361016 and 0361015

I/O specifications: Power supply - Motor

Item	Specification	Comment
Power supply		
Input voltage	12 VDC, ± 20% 24 VDC, ± 10% 36 VDC, ± 10%	Cable dimension: 2 x 2.5mm ² (2 x AWG14) for all different voltages.
Duty cycle	20% at max. load	Ambient temperature 25°C
Input current	2 - 21 Amp. depending on load and voltage (see graphs)	
Connection	To extend actuator: Connect Brown to positive Connect Blue to negative To retract actuator: Connect Brown to negative Connect Blue to positive	Actuator direction can be controlled with a double-throw switch with the middle position "off"

Connections diagram: For 36xxxx+0H/Pxxxxxx and 36xxxx+1H/Pxxxxxx

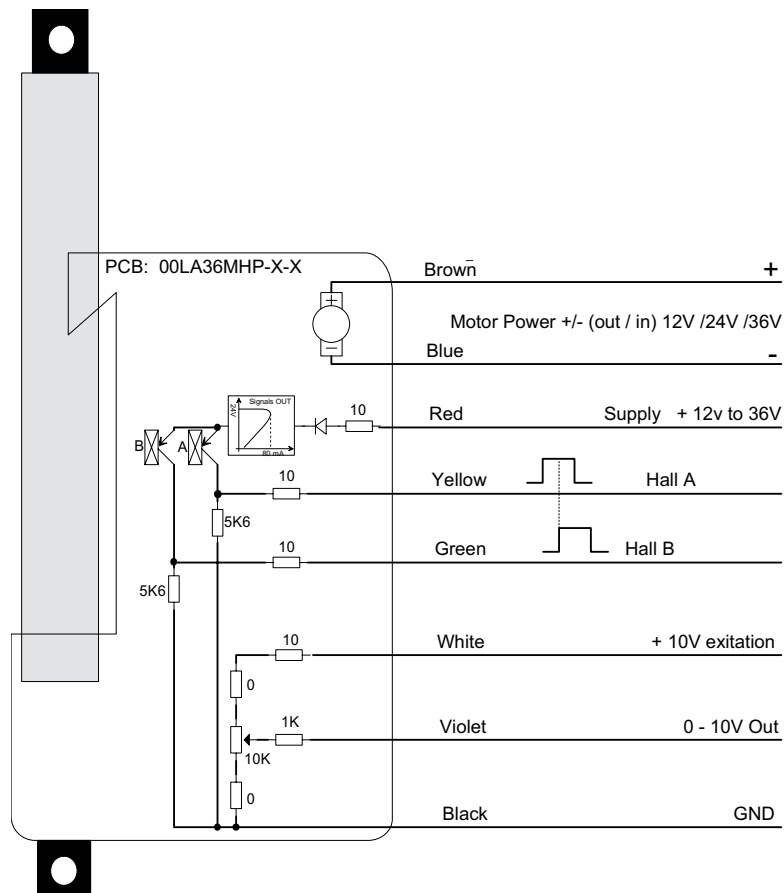

Connections diagram: For 36xxxx+30xxxB20, 36xxxx+3HxxxB20 and 36xxxx+40xxxB20

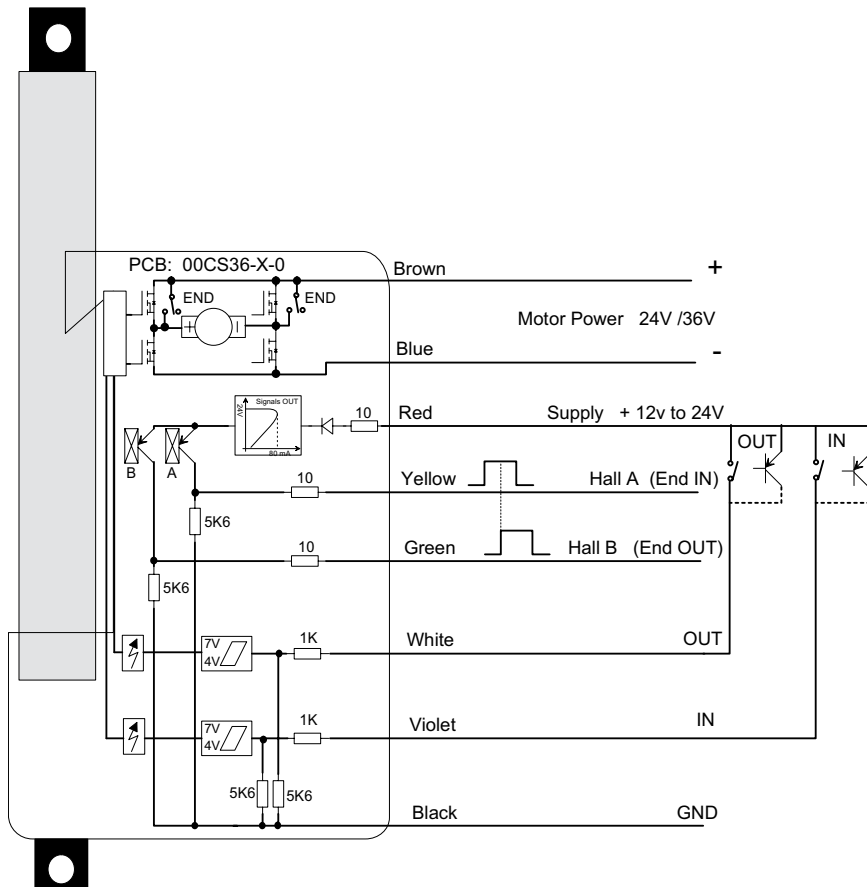

Connections diagram: For 36xxxx+ 2Pxxxxxx and 36xxxx+20xxxxxx:

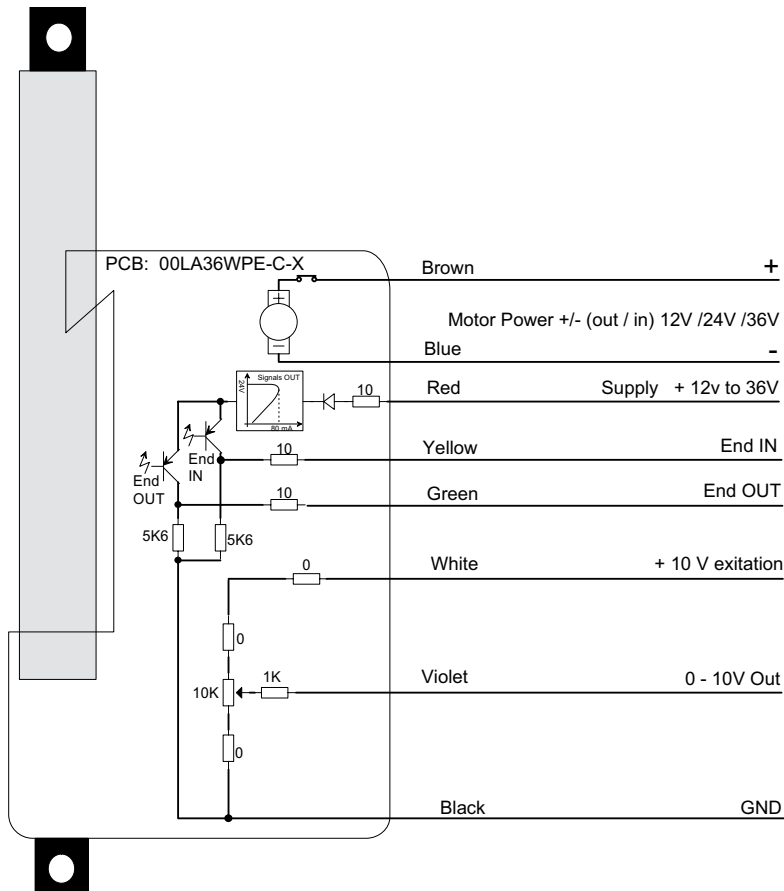

Note:
If you wish to use the endstop signals, you will have to keep power on the brown and blue wires, otherwise the signal will be lost.

Connections diagram: For 36xxxx+2Hxxxxxx:

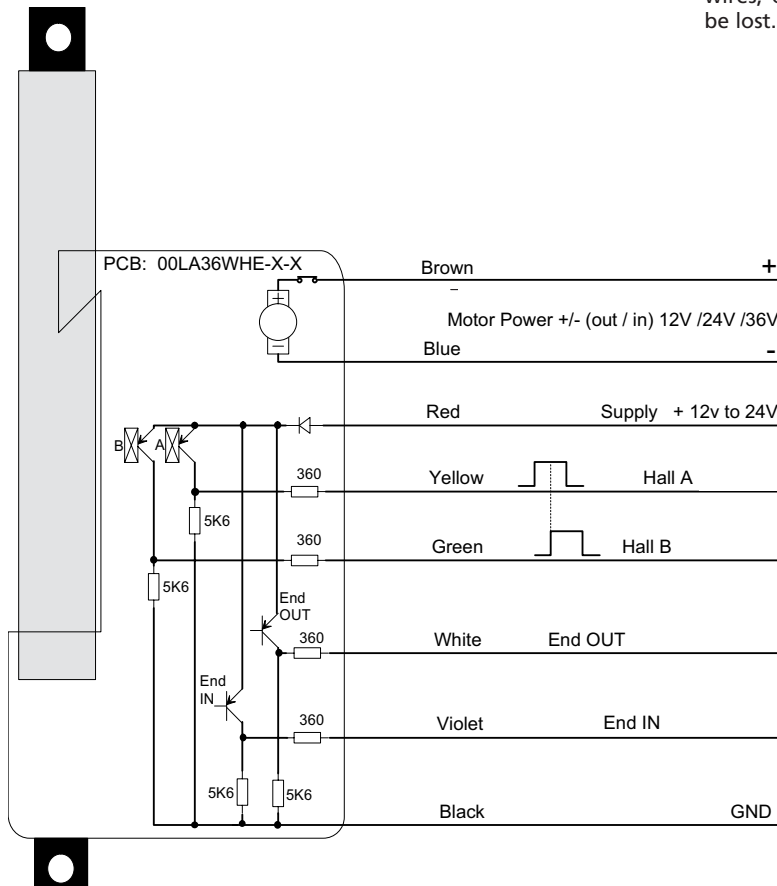

Positioning feedback – Hall sensors.

Item	Specification	Comment
Relative positioning		
Signal description	Can be used for both direction and positioning.	
Input Voltage	12 – 36V DC	Cable dimension: 6 x 0.5mm ² (6 x AWG20) for all different voltages.
Output voltage	Always the same as input voltage Note: max. output voltage 24 V DC	
Resolution (Distance the piston rod moves per count)	6800N: Actuator = 0.165517 mm per count. 4500N: Actuator = 0.253846 mm per count. 2600N: Actuator = 0.432558 mm per count. 1700N: Actuator = 0.72093 mm per count Movement per single Hall pulse: 6800N Actuator = 0.662068 mm per pulse 4500N Actuator = 1.015384 mm per pulse 2600N Actuator = 1.730232 mm per pulse 1700N Actuator = 2.88372 mm per pulse	The Hall sensor signals are generated by the turning of the actuator gearing. These signals can be fed into a PLC (Programmable Logic Controller). In the PLC the quadrature signals (fig. 1) can be used to register the direction and position of the piston rod.
Frequency	Frequency is 14-26 Hz on A signal (and the same on B signal) depending on load.	Low frequency with a high load. Higher frequency with no load.
Current consumption	15 mA	Also when actuator is not running.
Switching capacity	40 mA, max. pr. channel	Max. 680 nF
Connection	Supply = Red Hall A = Yellow Hall B = Green Common - = Black	
Diagram:	<p style="text-align: right;">Fig. 1</p>	

Positioning feedback – Potentiometer.

Item	Specification	Comment
Absolute positioning		
Potentiometer	Bourns 0-10 K ohm A 5%, 10-Turn	Type: 3540 Wirewound
Output range with 12 mm spindle pitch	0 K ohm = 0 mm stroke 10 K ohm = 500 mm stroke	The same for all LA36 12 mm models. e.g. 250 mm stroke = 5 Kohm.
Output range with 20 mm spindle pitch	0 K ohm = 0 mm stroke 10 K ohm = 833 mm stroke	The same for all LA36 20 mm models. e.g. 416.5 mm stroke = 5 Kohm.
Linearity	± 0.25%	
Output protection	1 Kohm protection resistor	
Connection	Common - = Black +10 V excitation = White 0 = 10 V out = Violet	+10 V or other value

Manual hand crank

The manual hand crank can be used in the case of power failure.

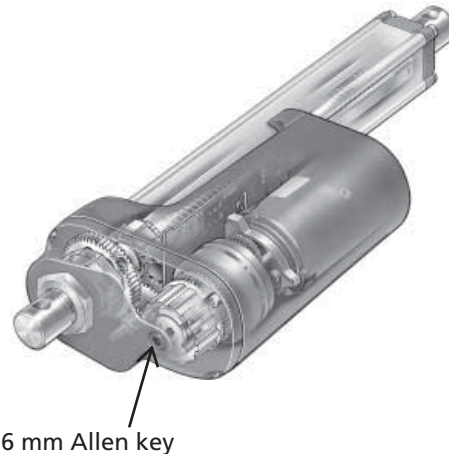

The cover over the Allen Key socket must be unscrewed before the Allen Key can be inserted and the Hand Crank operated.

Hand Crank Torque: 6 - 8 Nm (at maximum load)

Piston Rod movement per turn

Gear A = 10.5 mm
Gear B = 6.0 mm
Gear C = 4.0 mm



The power supply has to be disconnected during manual operation.

The LA36 is tested according to the following standards:

Test	Specification:	Comment
Cold test	EN60068-2-1 (Ab) EN60068-2-1 (Ad)	Storage at low temperature: -40°C Operating at low temperature: -30°C
Dry heat	EN60068-2-2 (Bb) EN60068-2-2 (Bd)	Storage at high temperature: +90°C Operating at high temperature: +65°C
Change of temperature	EN60068-2-14 (Na)	Rapid change in temperature: +100°C to -30°C
Damp heat	EN60068-2-30 (Db) EN60068-2-3 (Ca)	Damp heat, Cyclic: Relative humidity 93 - 98 % High +55°C, low +25°C Damp heat, Steady: Relative humidity 93 - 95 % +40°C ± 2°C
Salt spray	EN60068-2-52 (Kb)	Salt spray test: 500 hours incl. spraying periods + humidity storage
Degrees of protection	EN60529-IP66	IP 6X – Dust: Dust-tight IP X6 – Water: No ingress of water causing damage
Chemicals	B57691/96 hours	Resistant against: diesel, hydraulic oil, ethylene glycol, urea nitrogen, liquid lime, NPK fertilizers
Free fall		Free fall from all sides: 0.4 meters on to steel
Vibration	EN60068-2-36 (Fdb) EN60068-2-6 (Fc)	Random vibration: Short time 6.29 g RMS (Rod Mean Square) Long time 7.21 g RMS Sinus vibration: Freq. 5 - 25 Hz, amplitude = 3.3 mm pp Freq. 25 - 200 Hz, acceleration 4 g
Bump	EN60068-2-29 (Eb)	Bump test: Level 40 g for 6 milliseconds. 3,000 bumps
Shock	EN60068-2-27 (Ea)	Shock test: Level 100 g for 6 milliseconds
Power supply	ASAE EP455 (1990)	Operating voltages: +10 V - + 16V Over voltage +26(V) / 5 min
HF-immunity	EN61000-6-2	Level: 30V/m. at 26 MHz – 1,000 MHz; 80% 1 KHz
Emission	EN61000-6-4	All levels are well within the norms of the emission standards
Insulation test		Level: 500 V AC/25-100 Hz for 1 minute
Automotive transients	ISO 7637	Load dump test only accepted on motor power connection

Specifications subject to change without prior notice.

It is the responsibility of the product user to determine the suitability of LINAK A/S products for a specific application. LINAK will at point of delivery replace/repair defective products covered by the warranty if promptly returned to the factory. No liability is assumed beyond such replacement/repair.